

# ROTARY TILLER UH-SERIES



## PART'S MANUAL

**Tirth Agro Technology Pvt. Ltd.**

ISO 9001:2015 CE Certified Company



PM1129-21EN-012\_NOV\_20



# INDEX



<b>Page No.</b>	<b>Description</b>	<b>Revision Date</b>
1.1	ACCESSORIES PARTS	PM1129-21EN-012_REV_000_NOV_20
1.2	ACCESSORIES PARTS	PM1129-21EN-012_REV_000_NOV_20
2.1	MACHINE PARTS	PM1129-21EN-012_REV_000_NOV_20
2.2	MACHINE PARTS	PM1129-21EN-012_REV_000_NOV_20
3.1	GEAR BOX PARTS	PM1129-21EN-012_REV_000_NOV_20
3.2	GEAR BOX PARTS	PM1129-21EN-012_REV_000_NOV_20
4.1	SIDE DRIVE PARTS	PM1129-21EN-012_REV_000_NOV_20
4.2	SIDE DRIVE PARTS	PM1129-21EN-012_REV_000_NOV_20
5.1	STUB AXLE PARTS	PM1129-21EN-012_REV_000_NOV_20
5.2	STUB AXLE PARTS	PM1129-21EN-012_REV_000_NOV_20
6.1	ROTOR PARTS	PM1129-21EN-012_REV_000_NOV_20
6.2	ROTOR PARTS	PM1129-21EN-012_REV_000_NOV_20
7.1	CE KIT PARTS	PM1129-21EN-012_REV_000_NOV_20
7.2	CE KIT PARTS	PM1129-21EN-012_REV_000_NOV_20

# ACCESSORIES PARTS

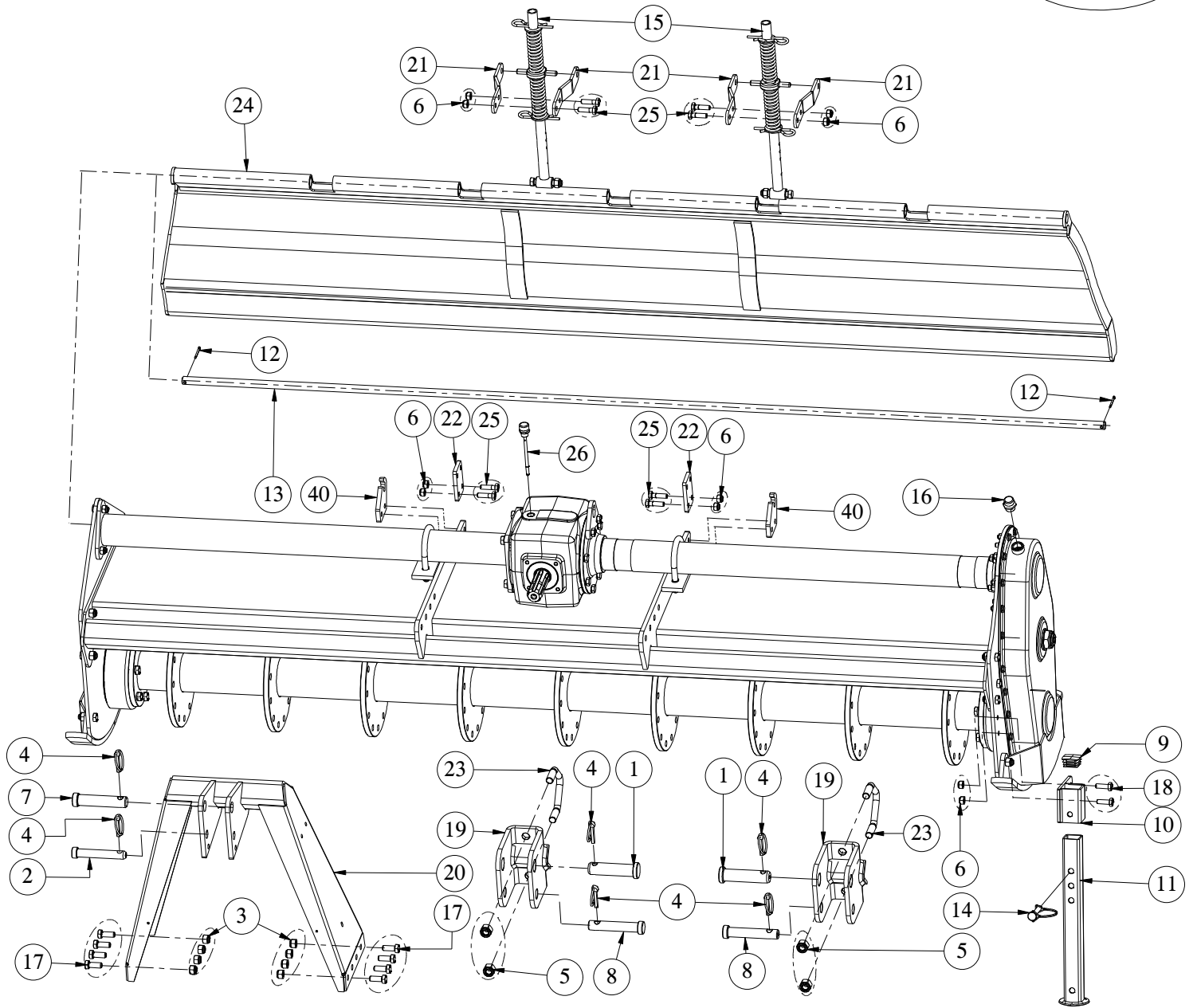

## CHAIN TYPE TRAILING BOARD

## OPTIONAL

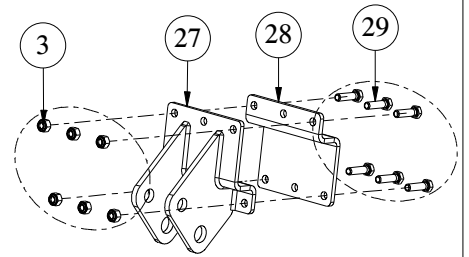
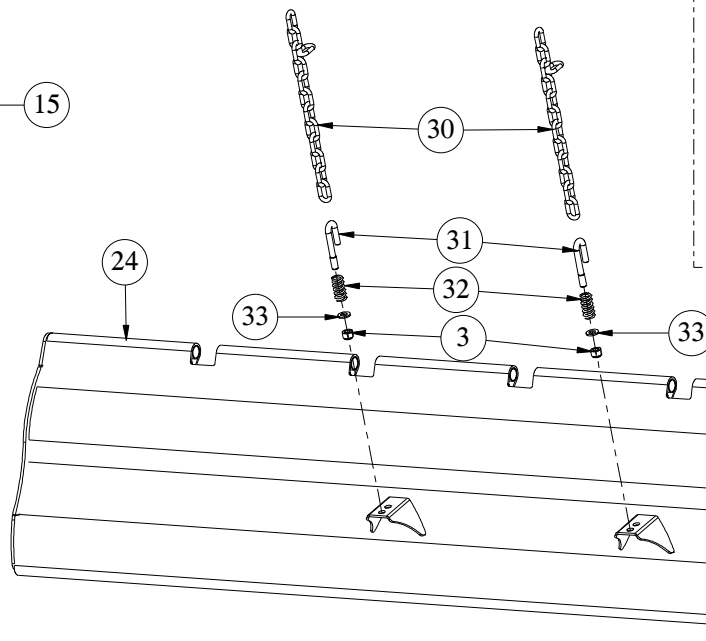
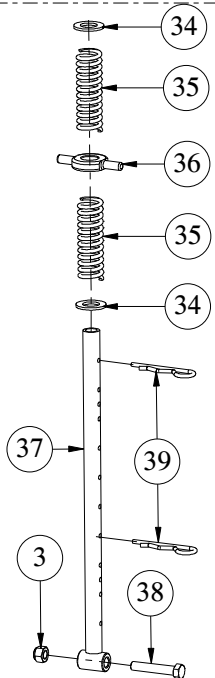

# ACCESSORIES PARTS



Sr. No.	Part No.	Description	Qty.
1	1217	HITCH PIN BOTTOM CAT-II (DIA-28 X 129)	2
2	1214	HINCH PIN TOP CAT-I (DIA- 19 X 126)	1
3	1209	NYLOCK NUT M12X1.75 (DIN-982)	10
		NYLOCK NUT M12X1.75 (DIN-982) (FOR DAMPAR SPRING TRAILING BOARD)	10
		NYLOCK NUT M12X1.75 (DIN-982) (FOR OPTIONAL HITCH BRACKET)	22
4	1218	LINCH PIN	6
5	1231	NYLOCK NUT M16X2.0 (DIN-982)	4
6	1298	NYLOCK NUT M10X1.50 (DIN-982)	10
7	1215	HINCH PIN TOP CAT-II (DIA- 25 X 126)	1
8	1216	HITCH PIN BOTTOM CAT-I (DIA-22 X 129)	2
9	4657	SQ. PIPE PLASTIC CAP 40MM	1
10	14104	SIDE STAND OUTER COMP	1
11	14105	SIDE STAND INNER COMP	1
12	19018	COTTER PIN (DIA 4 X 35)	2
13	14398	ROD, TB-L1542 (SRT-1.42)	1
	14282	ROD, TB-L1723 (SRT-1.60)	
	14249	ROD, TB-L1952 (SRT-1.80)	
	14168	ROD, TB-L2181 (SRT-2.10)	
14	14267	SQ. SNAPPER PIN D10 X L70	1
15	2302	DAMPER SPRING ASSY	2
16	14310	AIR BREATHER 1/2" BSP (1GTSR38)	1
17	17275	HEX BOLT M12X1.75X30(DIN933)(8.8)(ZP)	8
18	3340	HEX BOLT M10X1.50X30(DIN933)(8.8)(ZP)	2
19	14374	HITCHING BRACKET COMP	2
20	14377	TOP MAST COMP.	1
21	14400	BRACKET, DAMPER SPRING ASM.	4
22	14401	CONNECTION PLATE	2
23	14422	V-BOLT M16X2X104.5X104.5X40.5TL (8.8)	2
24	14399	TRAILING BOARD COMP (SRT-1.42)	1
	14283	TRAILING BOARD COMP (SRT-1.60)	
	14451	TRAILING BOARD COMP.(SRT-1.60) (FOR DAMPER SPRING)	
	14253	TRAILING BOARD COMP (SRT-1.80)	
	14407	TRAILING BOARD COMP.(SRT-1.80) (FOR DAMPER SPRING)	
	14151	TRAILING BOARD COMP (SRT-2.10)	
14458	TRAILING BOARD COMP.(SRT-2.10) (FOR DAMPER SPRING)		
25	3345	HEX BOLT M10X1.50X35(DIN931)(8.8)(ZP)	8
26	14316	DIPSTICK 106MM (M16 X 1.5) (1MLSR202)	1
27	14419	HITCHING BRACKET COMP (OPTIONAL)	2
28	14418	HITCHING BRACKET BEND PLATE (OPTIONAL)	2
29	3338	HEX BOLT M12X1.75X45(DIN931)(8.8)(ZP) (OPTIONAL)	12
30	14073	LIFTING CHAIN TB	2
31	14004	J-BOLT M12 x 1.75 x 24 x 87.5 x 25TL	2
32	14005	U-BOLT SPRING	2
33	8126	PLAIN WASHER 12MM (BS-4320)	2
34	2304	DAMPER SPRING WASHER	2
35	2305	DAMPER SPRING	2
36	2306	DAMPER SPRING COLLER	1
37	2303	DAMPER SPRING ROD COMP	1
38	2203	HEX BOLT M12X1.75X65(IS1364-1)(8.8)(ZP)	1
39	23068	R-CLIP D5 X L100 MM	2
40	11726	CHAIN LIFTING HOOK (FOR CHIAN)	2

# MACHINE PARTS

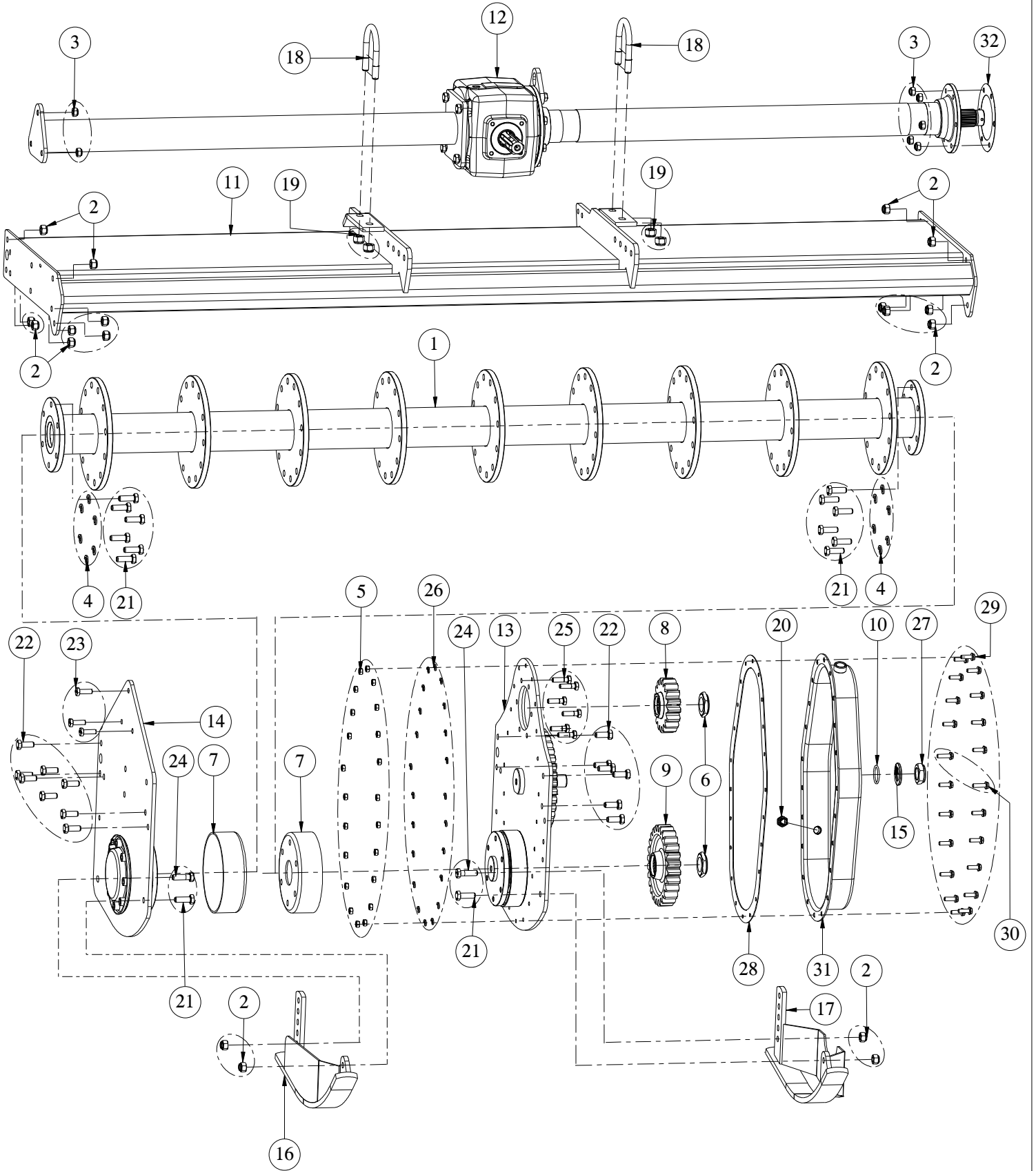

# MACHINE PARTS



Sr. No.	Part No.	Description	Qty.
1	-	ROTOR ASSEMBLY (SEE ROTOR PARTS PAGE)	1
2	1209	NYLOCK NUT M12X1.75 (DIN-982)	18
3	1298	NYLOCK NUT M10X1.50 (DIN-982)	9
4	1306	SPRING WASHER M12.00(IS 3063)	12
5	8181	HEX NUT M8X1.25(IS 1363)(8)(ZP)	22
6	1449	NYLOCK NUT M35X1.50	2
7	14130	DUST COVER	2
8	14138	SIDE GEAR 17 TEETH	1
9	14139	SIDE GEAR 26 TEETH	1
10	4663	O RING 35 X 3.5	1
11	14392	HULL COMP (SRT-1.42)	1
	14276	HULL COMP (SRT-1.60)	
	14250	HULL COMP (SRT-1.80)	
	14150	HULL COMP (SRT-2.10)	
12	-	GEAR BOX ASSEMBLY (SEE GEAR BOX ASSEMBLY PAGE)	1
13	-	R D PLATE ASSEMBLY (SEE SIDE DRIVE PARTS PAGE)	1
14	-	S D PLATE ASSEMBLY (SEE STUBE AXLE PARTS PAGE)	1
15	14161	SPACER 30x50x4	1
16	14163	DEPTH SKID COMP RH	1
17	14164	DEPTH SKID COMP LH	1
18	14167	U BOLT M14 X 2 X 88 X 115.40 X 30TL	2
19	1574	NYLOCK NUT M14X2.00 (DIN-982)	4
20	14314	OIL LEVEL GAUGE-3/8" BSP (1GTLA21O)	1
21	17274	HEX BOLT M12X1.75X35(DIN933)(8.8)(ZP)	14
22	17275	HEX BOLT M12X1.75X30(DIN933)(8.8)(ZP)	14
23	3340	HEX BOLT M10X1.50X30(DIN933)(8.8)(ZP)	3
24	3343	HEX BOLT M12X1.75X40(DIN931)(8.8)(ZP)	2
25	3345	HEX BOLT M10X1.50X35(DIN931)(8.8)(ZP)	6
26	14360	SPRING WASHER M8.00(IS 3063)(ZP)	22
27	14366	NYLOCK NUT M28 X 1.50	1
28	14383	CHAIN COVER PAPER GASKET	1
29	14441	FLANGE BOLT M8X1.25X25(DIN6921)(8.8)(ZP)	20
30	14442	FLANGE BOLT M8X1.25X30(DIN6921)(8.8)(ZP)	2
31	14449	SIDE COVER GD COMP V-1	1
32	14433	HOUSING FLANGE SMALL GASKET 0.5 NA	1

# GEAR BOX PARTS

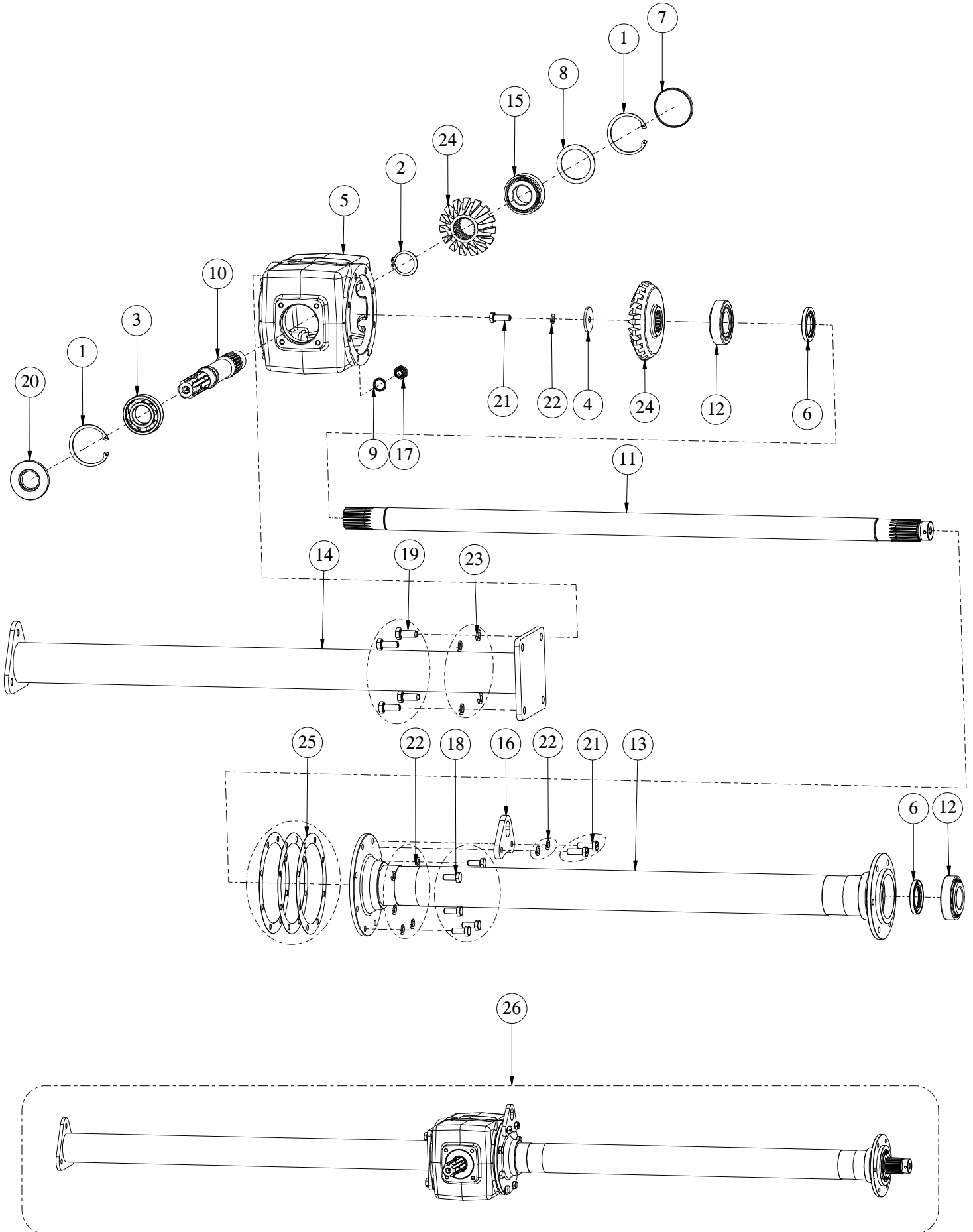



# GEAR BOX PARTS



Sr. No.	Part No.	Description	Qty.
1	1002	CIRCLIP INTERNAL 72mm	2
2	8027	CIRCLIP EXTERNAL 40MM	1
3	10143	BEARING 6207	1
4	14049	CROWN WASHER	1
5	14144	GEAR BOX 540 RPM	1
6	14121	OIL SEAL 40 x 62 x 7	2
7	14119	OIL SEAL 72 x 8	1
8	14120	SPACER 71.50 x 56 x 3	1
9	19007	DOWTY SEAL (3/8 BSP)	1
10	14146	INPUT SHAFT 540	1
11	14395	JACK SHAFT (TL-791) (SRT-1.42)	1
	14279	JACK SHAFT 883MM (SRT-1.60)	
	14248	JACK SHAFT 995MM (SRT-1.80)	
	14147	JACK SHAFT 1110.50MM (SRT-2.10)	
12	14149	BEARING 32208	2
13	14393	J/S HSG. (J-791) (EL-667.3) (SRT-1.42)	1
	14277	J/S HSG. (J-883) (EL-757.8) (SRT-1.60)	
	14254	J/S HSG. (J-995) (EL-869.8) (SRT-1.80)	
	14153	J/S HSG.(J-1110.5)(EL-985.5) (SRT-2.10)	
14	14394	FULL HSG COMP (TL-663.9) (SRT-1.42)	1
	14278	FULL HSG COMP (TL-754.4) (SRT-1.60)	
	14255	FULL HSG COMP (TL-870.9) (SRT-1.80)	
	14154	FULL HSG COMP (TL-983.9) (SRT-2.10)	
15	14155	BEARING 32207	1
16	14178	GEAR BOX LIFTING HOOK	1
17	14312	DRAIN CAP 3/8" BSP (1GTC02UW)	1
18	17270	HEX BOLT M10X1.50X25(DIN933)(8.8)(ZP)	6
19	17275	HEX BOLT M12X1.75X30(DIN933)(8.8)(ZP)	4
20	14309	OIL SEAL 35 X 72 X 8 (SPECIAL)	1
21	3340	HEX BOLT M10X1.50X30(DIN933)(8.8)(ZP)	3
22	14361	SPRING WASHER M10.00(IS 3063)(ZP)	9
23	14362	SPRING WASHER M12.00(IS 3063)(ZP)	4
24	14370	CROWN T22,PINION T15 PAIR	1
25	14432	HOUSING FLANGE BIG GASKET (U/H) 0.5 NA	3
26	14396	GEAR BOX ASSM. (SRT-1.42)	1
	14280	GEAR BOX ASSEMBLY (SRT-1.60)	
	14251	GEAR BOX ASSEMBLY (SRT-1.80)	
	14156	GEAR BOX ASSEMBLY (SRT-2.10)	

# SIDE DRIVE PARTS

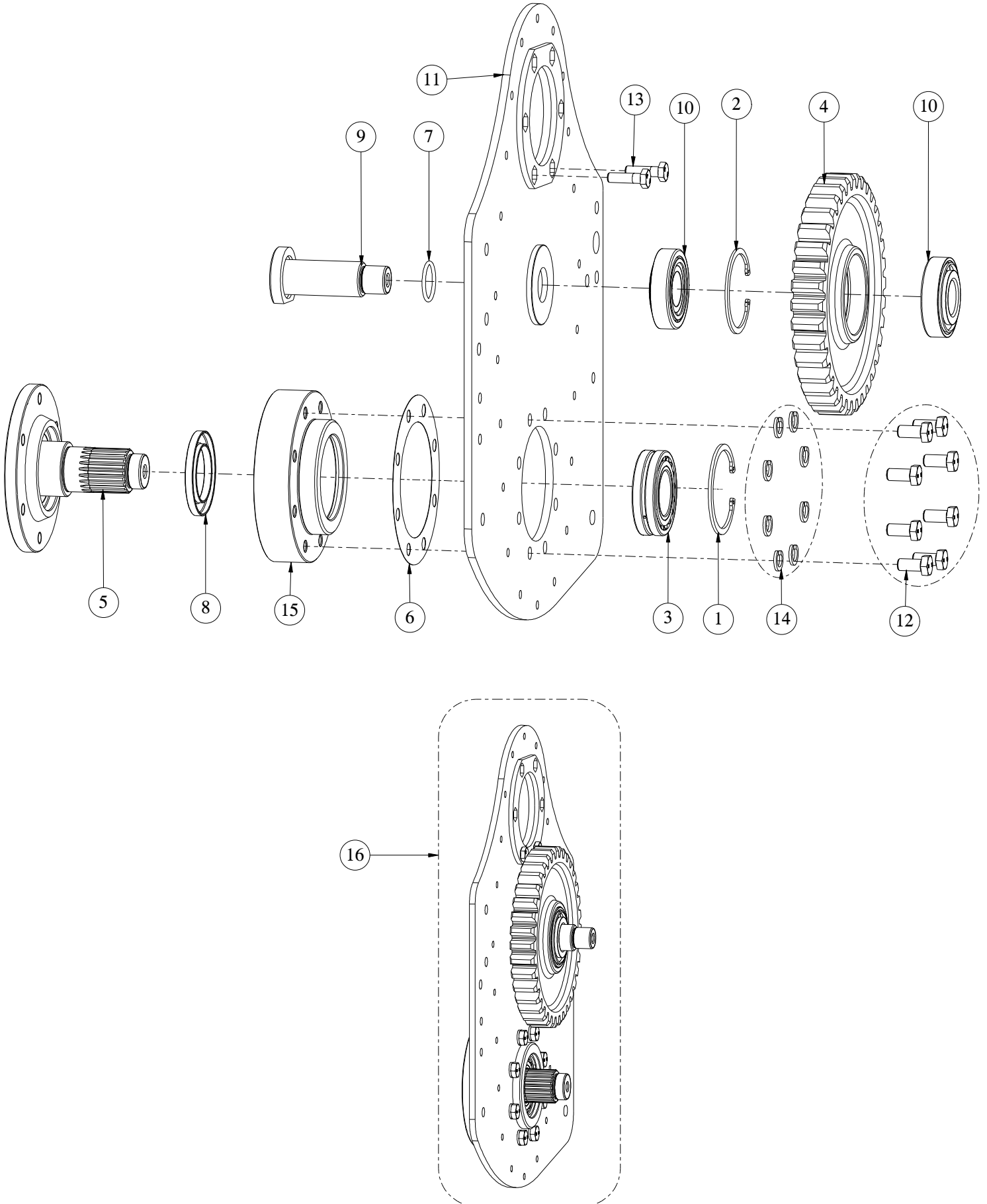

# SIDE DRIVE PARTS



Sr. No.	Part No.	Description	Qty.
1	1049	CIRCLIP INTERNAL 85mm	1
2	1130	CIRCLIP INTERNAL 80MM	1
3	8268	BEARING 22209	1
4	14140	SIDE GEAR 36 TEETH	1
5	14145	R D SHAFT GEAR SIDE	1
6	14431	R D HOUSING GASKET 0.5 NA	1
7	4663	O RING 35 X 3.5	1
8	14128	OIL SEAL 85 X 55 X 8	1
9	14148	R D SHAFT MIDDLE	1
10	14177	BEARING 30307	2
11	14157	R D PLATE GD COMP	1
12	17474	HEX BOLT M12X1.75X25(DIN933)(8.8)(ZP)	8
13	3345	HEX BOLT M10X1.50X35(DIN931)(8.8)(ZP)	2
14	14362	SPRING WASHER M12.00(IS 3063)(ZP)	8
15	14440	ROTOR SHAFT HOUSING V1	1
16	14158	R D PLATE ASSEMBLY	1

# STUB AXLE PARTS

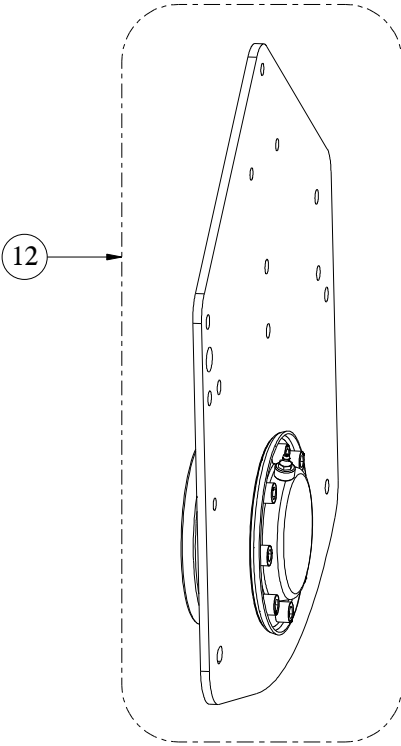
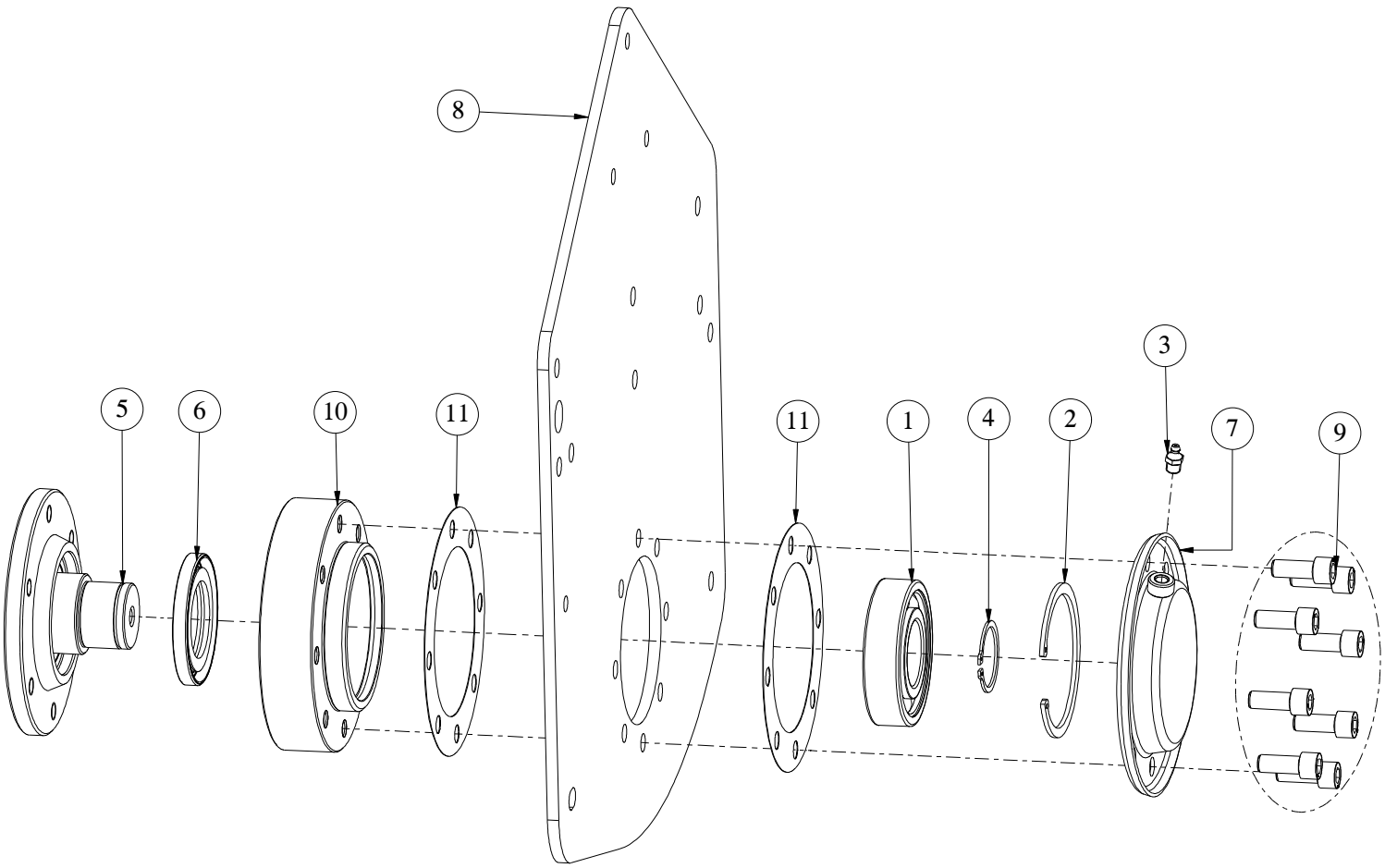

# STUB AXLE PARTS



Sr. No.	Part No.	Description	Qty.
1	1073	BEARING 6309 LU	1
2	1074	CIRCLIP INTERNAL 100MM	1
3	1253	1/8 BSP GREASE NIPPLE 7.5MM	1
4	2089	CIRCLIP EXTERNAL 45MM	1
5	14117	STUB AXLE SHAFT SD SIDE	1
6	14122	OIL SEAL 55 x 90 x 10	1
7	14102	STUB AXLE END COVER COMP	1
8	14179	S D PLATE	1
9	14367	ALLEN BOLT M12X1.75X30-FT12.9DIN912-ZINC	8
10	14439	ROTOR SHAFT HOUSING V1	1
11	14431	R D HOUSING GASKET 0.5 NA	2
12	14159	S D PLATE ASSEMBLY	1

# ROTOR PARTS

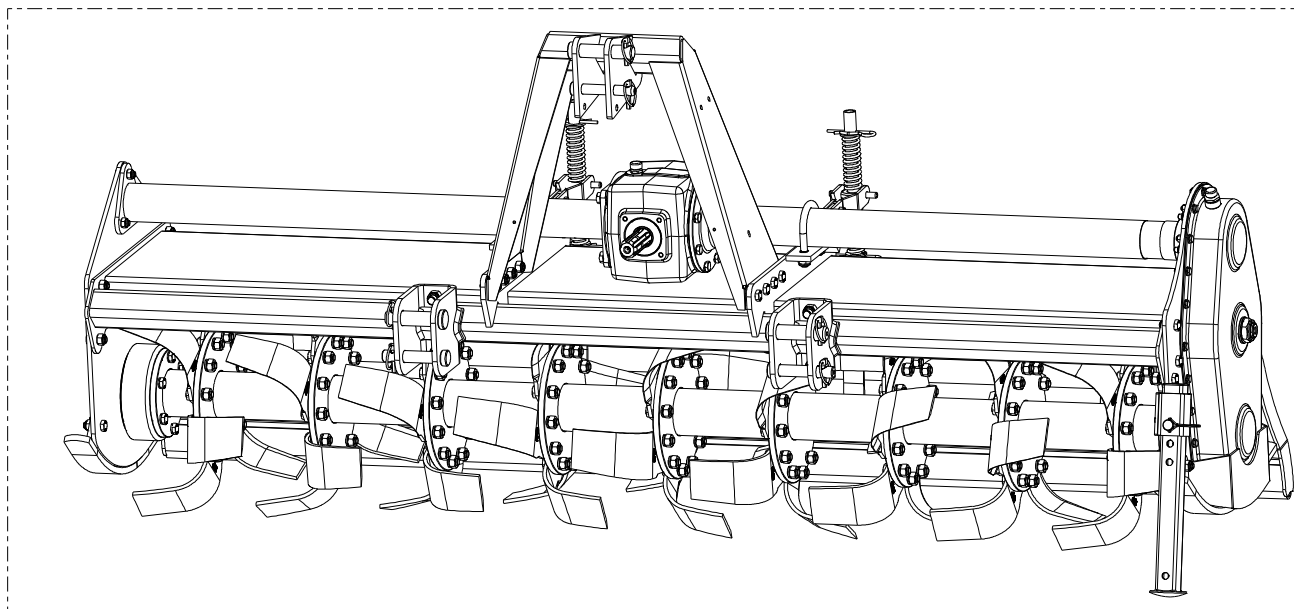
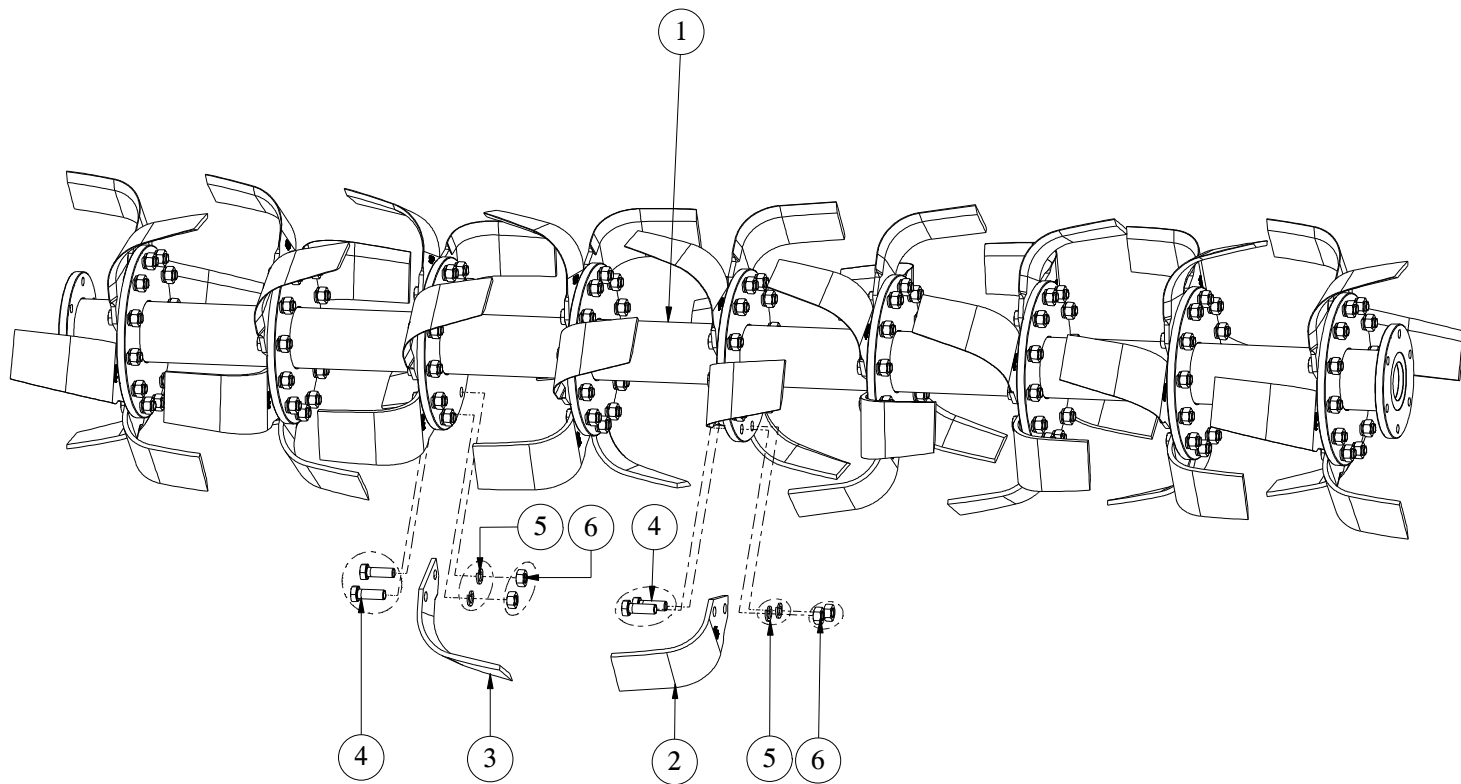

# ROTOR PARTS



Sr. No.	Part No.	Description	Qty.
1	14397	ROTOR COMP (SRT-1.42)	1
	14281	ROTOR COMP (SRT-1.60)	
	14252	ROTOR COMP (SRT-1.80)	
	14152	ROTOR COMP (SRT-2.10)	
2	3126	BLADE C-TYPE LH (80X7)	AS REQ.
3	3127	BLADE C-TYPE RH (80X7)	AS REQ.
4	14337	HEX BOLT M14X1.50X40(DIN931)(10.9)(ZP)	AS REQ.
5	14363	SPRING WASHER M14.00(IS 3063)(ZP)	AS REQ.
6	14338	HEX NUT M14 X 1.50 (10.9) DIN934	AS REQ.

# CE KIT PARTS

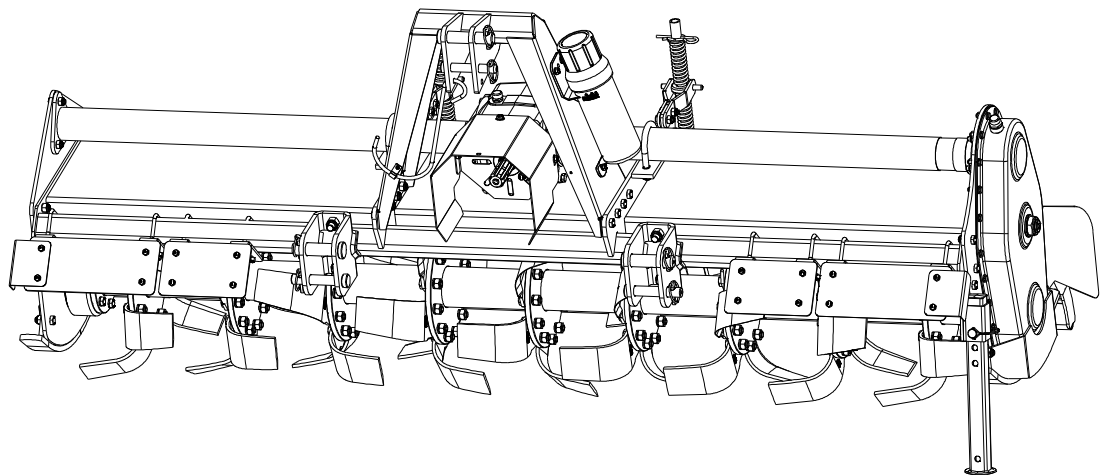
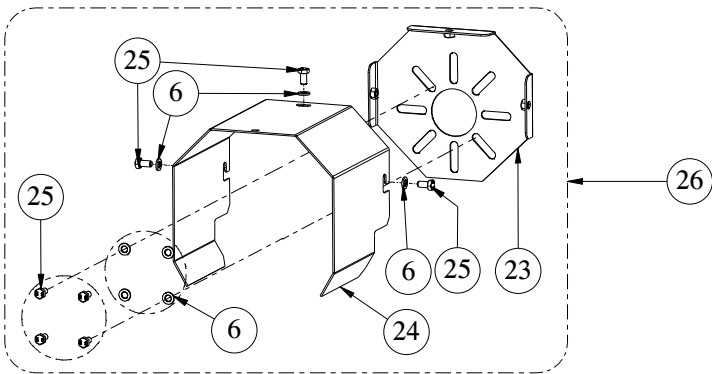
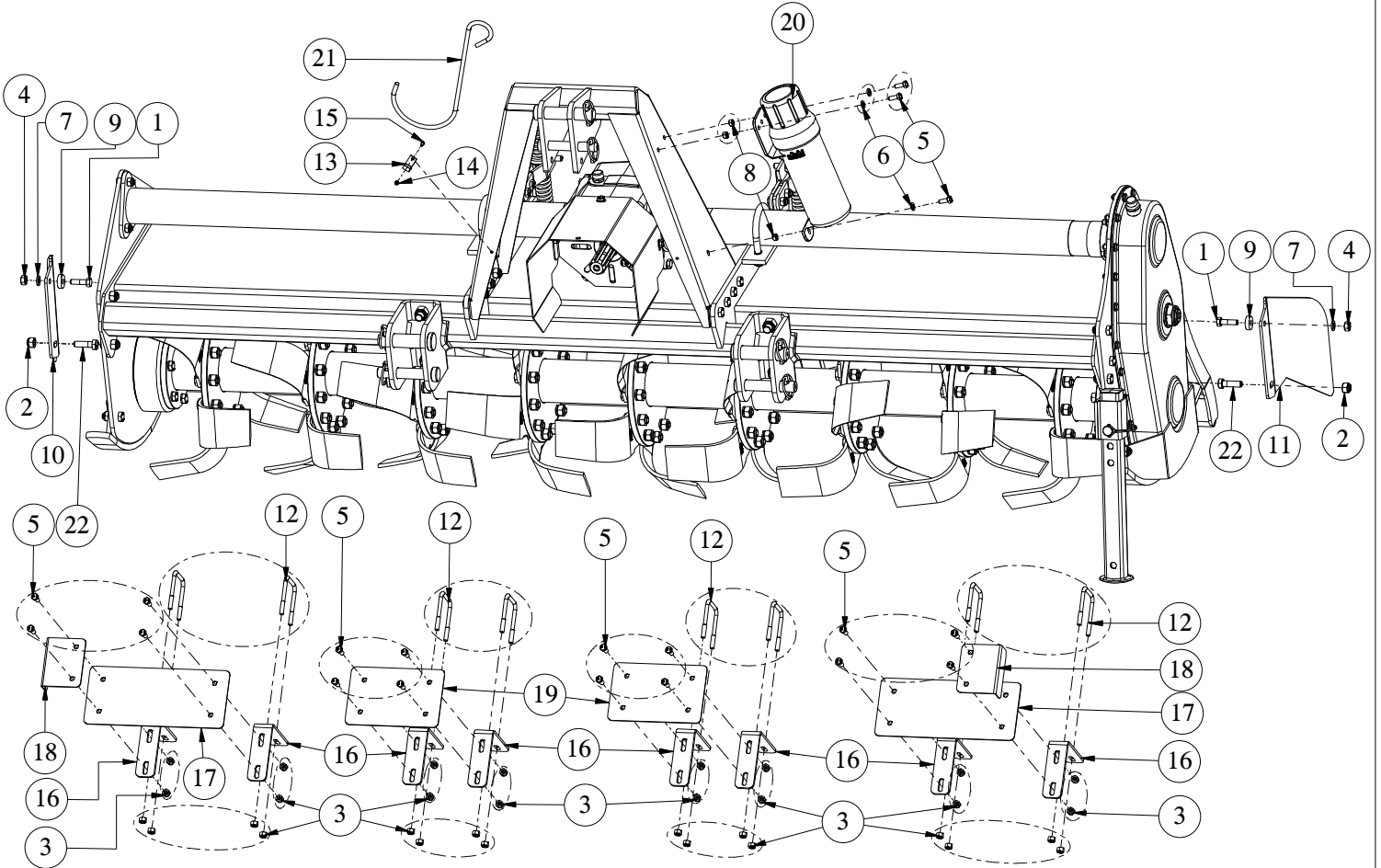



# CE KIT PARTS



Sr. No.	Part No.	Description	Qty.
1	6068	HEX BOLT M10X1.50X35(IS1364-1)(8.8)(ZP)	2
2	1209	NYLOCK NUT M12X1.75 (DIN-982)	2
3	1297	NYLOCK NUT M8X1.25 (DIN-982) (SRT-1.42)	16
		NYLOCK NUT M8X1.25 (DIN-982) (SRT-1.60)	
		NYLOCK NUT M8X1.25 (DIN-982) (SRT-1.80)	32
		NYLOCK NUT M8X1.25 (DIN-982) (SRT-2.10)	
4	1299	HEX NUT M10X1.50(IS 1363)(8)(ZP)	2
5	8040	HEX BOLT M8X1.25X20(IS1364-2)(8.8)(ZP) (SRT-1.42)	11
		HEX BOLT M8X1.25X20(IS1364-2)(8.8)(ZP) (SRT-1.60)	
		HEX BOLT M8X1.25X20(IS1364-2)(8.8)(ZP) (SRT-1.80)	19
		HEX BOLT M8X1.25X20(IS1364-2)(8.8)(ZP) (SRT-2.10)	
6	8064	PLAIN WASHER 8MM (BS-4320)	10
7	8078	PLAIN WASHER 10MM (BS-4320)	2
8	8181	HEX NUT M8X1.25(IS 1363)(8)(ZP)	3
9	14194	SPACER DIA-28 x 11 x 8 MM	2
10	14214	TB GAURD PLATE LH	1
11	14215	TB GAURD PLATE RH	1
12	37088	U-BOLT M8X1.25X69X80X28TL (8.8) (SRT-1.42)	4
		U-BOLT M8X1.25X69X80X28TL (8.8) (SRT-1.60)	
		U-BOLT M8X1.25X69X80X28TL (8.8) (SRT-1.80)	8
		U-BOLT M8X1.25X69X80X28TL (8.8) (SRT-2.10)	
13	23147	PLATE,HOOK HOLDING	1
14	24529	NYLOCK NUT M4X0.7(IS-7002)(8)(ZP)	1
15	35098	HEX BOLT M4X0.7X15(IS1364-2)(8.8)(ZP)	1
16	14452	BRACKET,FRONT BARRIER (SRT-1.42)	4
		BRACKET,FRONT BARRIER (SRT-1.60)	
		BRACKET,FRONT BARRIER (SRT-1.80)	8
		BRACKET,FRONT BARRIER (SRT-2.10)	
17	4740	PLATE,FRONT BARRIER (L=300) (SRT-1.42)	2
		PLATE,FRONT BARRIER (L=300) (SRT-1.60)	
		PLATE,FRONT BARRIER (L=300) (SRT-1.80)	
		PLATE,FRONT BARRIER (L=300) (SRT-2.10)	
18	4741	PLATE,END,FRONT BARRIER	2
19	14326	PLATE,FRONT BARRIER (125 X L=200) (SRT-2.10)	2
	4739	PLATE,FRONT BARRIER (L=100) (SRT-1.80)	
20	26030	MANUAL BOX COVER 1/2	1
21	14341	DRIVELINE HOOK 320MM	1
22	3343	HEX BOLT M12X1.75X40(DIN931)(8.8)(ZP)	2
23	1546	PTO SHAFT GUARD MOUNT PLATE COMP	1
24	17558	PTO SHAFT GUARD (BMF)	1
25	8190	HEX BOLT M8X1.25X15(IS1364-2)(8.8)(ZP)	7
26	1547	PTO SHAFT GUARD ASSEMBLY	1







**TirthAgroTechnologyPvt.Ltd.**

“SHAKTIMAN”, Survey No.-108/1,

Plot No. B,NH-27, Nr. Bharudi Toll Plaza,

Bhunava (Village), Taluka: Gondal,

Dist.: Rajkot – 360311,

State: Gujarat- INDIA,

Phone: + 91(2827) 661637 / 270537

Fax: + 91(2827) 270457

e-mail: [info@shaktimanagro.com](mailto:info@shaktimanagro.com)

[www.shaktimanagro.com](http://www.shaktimanagro.com)