



TILLER

RD /110•120•135•150•160•185•210

USER AND MAINTENANCE MANUAL



Medium-heavy fixed tiller



TRANSLATED INSTRUCTIONS
903826002~02



CONTENTS

1.	INTRODUCTION	5
1.1	SOME NOTES REGARDING THE USER MANUAL	5
1.2	DECLARATION OF CONFORMITY	6
1.3	DELIVERY LETTER	7
1.4	TILLER IDENTIFICATION AND MANUAL CODE	7
1.5	GENERAL DELIVERY NOTES	8
1.6	TILLER COMPOSITION	9
2.	SAFETY	10
2.1	LIST OF RESIDUAL RISKS	10
2.2	SAFETY PRESCRIPTIONS	10
2.3	DEFINITIONS	10
2.4	CONVENTIONAL SYMBOLS	11
2.5	OPERATOR REQUIREMENTS	11
2.6	CLOTHING AND PPE	12
2.7	SAFE USE OF THE MACHINE	12
2.8	INTENDED USE	12
2.9	SAFETY DEVICES	13
2.10	POSITION AND MEANING OF THE PICTOGRAMS	13
3.	UNLOADING AND UNPACKING THE TILLER	16
3.1	TILLER PROTECTED BY HEAT-SHRINKABLE FILM	16
3.2	TILLER PACKAGED IN WOODEN BOX	17
4.	TECHNICAL SPECIFICATIONS	18
5.	START-UP	19
5.1	CONNECTING THE TILLER TO THE TRACTOR	19
5.2	PTO DRIVE SHAFT COUPLING	20
5.3	CHECK THE STABILITY OF THE TRACTOR-TILLER COMPLEX	21
5.4	ROAD TRANSPORT	21
6.	ADJUSTMENTS	22
6.1	ROTOR GEARBOX	22
6.2	CLUTCH ADJUSTMENT	23
6.3	WORK HEIGHT ADJUSTMENT	23
6.4	REAR BONNET ADJUSTMENT	24
7.	USE	24
8.	STOPS	25
9.	CLEANING	26
10.	ROUTINE MAINTENANCE	27
10.1	CONTROL AND REPLACEMENT OF THE OIL IN THE GEARBOX ASSEMBLY	28
10.2	CONTROL AND REPLACEMENT OF THE OIL IN THE LATERAL DRIVE SUMP	29
10.3	CONTROL AND REPLACEMENT OF THE OIL IN THE EXTERNAL ROTOR LATERAL SUPPORT	29
10.4	GREASING	30
10.5	HOE REPLACEMENT	30
11.	PTO DRIVE SHAFT	31
12.	STORAGE AND WINTERING	31



13.	SCRAPPING	31
14.	QUICK CONSULTATION TABLES	32
14.1	TABLE OF TIGHTENING TORQUES	32
14.2	TROUBLESHOOTING	32
14.3	LUBRICATION INTERVALS	33
15.	SPARE PARTS	34
16.	WARRANTY	34



Thank you for purchasing an

RD Tiller

The RD Tiller is manufactured by SICMA S.p.A, which has been manufacturing agricultural machines for over 40 years.

The RD Tiller has all safety and quality requisites required for this type of equipment.

Remember that to get the best performance and to maximize the productivity features, you must thoroughly know the instructions and information contained in this manual and follow them.

1. INTRODUCTION

1.1 SOME NOTES REGARDING THE USER MANUAL

It is important to know that the USER MANUAL is not an accessory of the Tiller, but an INTEGRAL PART and a SAFETY MEASURE (EN 12100-1).

For this reason:

- Keep it in good condition;
- Store it inside the document holder canister affixed to the Tiller;
- Hand it over to any operator, maintenance technician, handler or subsequent owner.

In this way, the Tiller can be used at its full potential in utmost safety.

The manual must remain intact, complete with all its pages and must be kept away from moisture and heat; during its consultation, prevent it from becoming wet or dirty to guarantee optimum legibility.

In case of loss or deterioration of this manual, request a copy from the Manufacturer or from the nearest Dealer including the identification code on the cover.

To ease consultation, the manual has been divided into parts, so that every phase can be easily understood.

With these precautions, SICMA intends to unequivocally draw the operator's attention to any hazardous situations that may arise.

We also remind you that the information, descriptions and illustrations contained in this manual reflect the state of the art at the time of marketing the machine.

The Manufacturer reserves the right to make, at any time, any changes to the machines for technical or commercial reasons. These changes do not require the Manufacturer to act on vehicles sold so far, nor to consider the present publication inadequate.

Any additions that the Manufacturer deems appropriate to provide later, will need to be kept with the manual and considered to be part of it.



WARNING!

The drawings and any other documents delivered together with the tiller are the property of SICMA which reserves all rights thereof and, therefore, cannot be disclosed to third parties without its written consent. Therefore, any reproduction, even partial, of the text and illustrations is strictly prohibited.



1.2 DECLARATION OF CONFORMITY

The machine is delivered accompanied by the following Declaration of Conformity.

EC DECLARATION OF CONFORMITY

The company

Sicma s.p.a. - C.da Cerreto, 39 - 66010 Miglianico (Ch) - Italy
Tel.: +39 0871 95841 - Fax: +39 0871 950295
e-mail: info@sicma.it - http://www.sicma.it

hereby declares that:

product: TILLER
model: RD
serial number:

complies with the essential requirements for safety and health of Directive 2006/42/CE.

To fulfil the above mentioned Directive have been applied the following harmonised standards:

-UNI EN ISO 4254-1:2010, EN ISO 4254-5:2009, UNI EN ISO 12100-1:2009, UNI EN ISO 12100-2:2009

and the technical standards and specifications

- ISO 11684:1995, ISO 13852:1996, UNI 9456:1989.

The person authorised to compile the technical file is Mr. Lorenzo Aurora



Miglianico, 15/03/2020
Chiara Aurora
AMMINISTRATORE UNICO



1.3 DELIVERY LETTER

The Tiller was designed in compliance with the Directive 2006/42/EC and was designed observing the guidelines of the technical standards relative to tillers, specifically UNI EN ISO 4254-1:2010 and UNI EN ISO 4254-5:2009.

Therefore, the machine does not represent a danger for the operator if used according to the instructions in this manual and on condition that the safety devices are kept constantly efficient.

This form evidences receipt of the Tiller:

- All safety devices are present;
- This use and maintenance manual is delivered with it.



WARNING!

SICMA POINTS OUT THAT ANY CHANGES TO OR TAMPERING WITH THE TILLER OR ANY OPERATION PERFORMED THAT IS NOT IN ACCORDANCE WITH WHAT IS PRESCRIBED IN THIS MANUAL, IN PARTICULAR FAILURE TO COMPLY WITH THE SAFETY REQUIREMENTS, AS WELL AS INVALIDATING THE WARRANTY, EXEMPTS SICMA FROM ANY LIABILITY FOR DAMAGES TO PROPERTY AND PERSONS.

Some of the devices described in this manual may not be present on your machine, as they vary depending on the chosen set up and the market of destination.

1.4 TILLER IDENTIFICATION AND MANUAL CODE

For any after-sales requests or information regarding the Tiller, contact SICMA or its after-sales centres, stating the model and the serial number on the plate.

The identification code of this manual is indicated on the cover. Take note of the number so that, in the event that this manual is lost or damaged, a copy may be requested from SICMA or from your nearest dealer, quoting the serial number indicated on the CE plate.



1



1.5 GENERAL DELIVERY NOTES

The Tiller, its parts and accessories are normally delivered by lorry or container. Upon receipt of the machine, check that the details of delivery correspond to the order specifications (see packing slip or packing list) and that there is no damage to the Tiller or to its accessories.

Spare parts or ancillary equipment are sometimes placed in separate containers.

In the event of damage or missing parts immediately inform SICMA or its local representatives, the carrier or its insurance agent, providing details and/or photos.

The Tiller is delivered by SICMA equipped with the following:

- 1 - PTO DRIVE SHAFT;
- 2 - TILLER USE AND MAINTENANCE MANUAL
- 3 - PTO DRIVE SHAFT USE AND MAINTENANCE MANUAL;
- 4- CE DECLARATION OF CONFORMITY.

2

English

TILLER

RD /110-120-135-150-160-185-210
USER AND MAINTENANCE MANUAL



Medium-heavy fixed tiller

TRANSLATED INSTRUCTIONS
993520002-02



3

Manuale di uso e manutenzione



EN Users manual
DK Brugsanvisning
S Instruktionsmanual
N Instruktionsmanual
FIN Käyttöohje
PL Instrukcja obsługi

Code: 1140917 - D



EUROCARDAN
ENERGY ON THE MOVE

4

EC DECLARATION OF CONFORMITY

The company

Sicma s.p.a. - C.da Cerreto, 39 - 66010 Miglianico (Ch) - Italy
Tel.: +39 0871 95841 - Fax: +39 0871 950295
e-mail: info@sicma.it - http://www.sicma.it

hereby declares that:

product: TILLER
model: RD
serial number:

complies with the essential requirements for safety and health of Directive 2006/42/CE.

To fulfill the above mentioned Directive have been applied the following harmonised standards:
-UNI EN ISO 4254-1:2010, EN ISO 4254-5:2009, UNI EN ISO 12100-1:2009, UNI EN ISO 12100-2:2009

and the technical standards and specifications
- ISO 11684:1995, ISO 13852:1996, UNI 9456:1989.

The person authorised to compile the technical file is Mr. Lorenzo Aurora

SICMA

Miglianico, 15/03/2020
Chiara Aurora
AMMINISTRATORE UNICO

Chiara Aurora

1.6 TILLER COMPOSITION

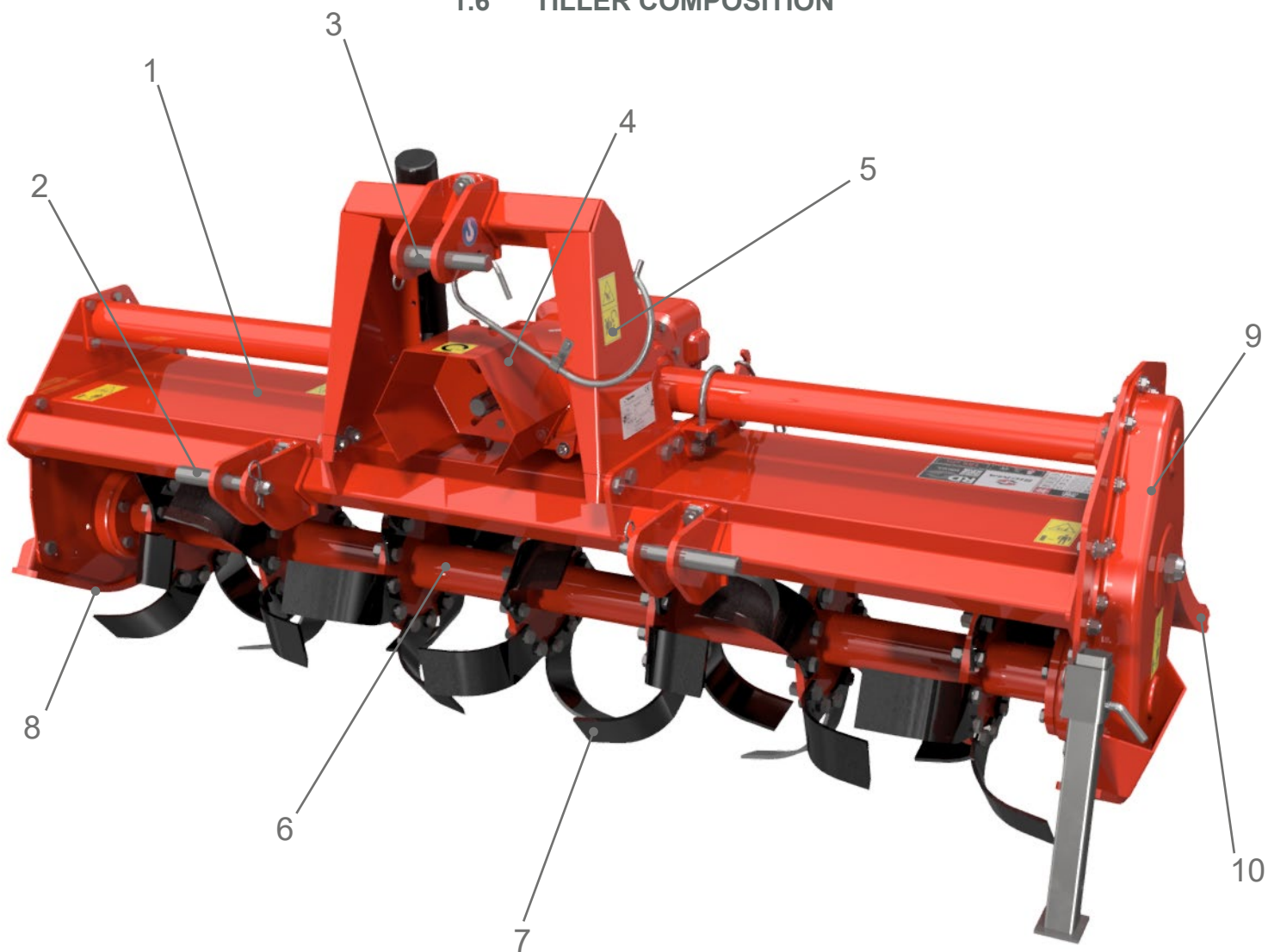

Ref.	Description
1	Body
2	Lower point hitches
3	Upper third point hitch
4	PTO drive shaft protection
5	Third point mast
6	Rotor
7	Hoes
8	Side skids
9	Drive sump
10	Rear hood



2. SAFETY

2.1 LIST OF RESIDUAL RISKS

Even though SICMA has done everything possible to ensure that the equipment meets the current safety standards as laid down in 2006/42/CE Directive, some residual risks, although reduced, still persist:

- CUTTING HAZARD DUE TO CONTACT WITH TOOLS (rotor);
- ENTANGLEMENT/Dragging HAZARD (rotor and PTO drive shaft);
- LIMB SHEARING HAZARD (rear covers);
- OVERTURNING/CRUSHING HAZARD (Tiller handling);
- BURN HAZARD (gearbox)

Therefore, whoever uses the machine or maintains it, must be a trained person aware that, despite using all the protections provided for by current regulations, there is still the possibility of the persistence of risks for the physical safety of operators and for the integrity of the equipment itself.

WARNING!

Tiller operators must read and understand the use and maintenance manual and ALWAYS ensure it is readily available in order to be able to consult it for any requirement.

The use and maintenance manual specifies all the information required by point 1.7.4 (instructions for use) of Annex 1 of the Machinery Directive, and a specific request is made to observe the requirements to avoid the occurrence of accidents that can cause damage to property or injury to persons.

2.2 SAFETY PRESCRIPTIONS

Any operator, before using the equipment, categorically **MUST** have read and understood the safety instructions and the entire manual.

- The machine is not suitable for use in sectors other than in agriculture: use other than the one specified is considered improper.
- The manual must always be readily available so that it can be consulted if necessary. If it is lost or damaged, it will be necessary to request a replacement copy from SICMA.
- For no reason climb, seat or lean on the equipment whether it is ON, OFF or in Zero Energy State.
- The operator must ensure that during operation of the machine no person is standing within its range of action. Never operate the machine near people standing or passing within the operating range of the machine.

2.3 DEFINITIONS

In this use and maintenance manual and on the equipment itself, it is possible to find several symbols whose meanings are illustrated below.

HAZARD:

A potential source of physical injury or damage to health.

HAZARDOUS AREA:

Any area within and/or in proximity of a machine in which the presence of a person constitutes a risk for the safety and health of the same.

The hazardous area is the area around the machine (connected to the tractor) up to a distance of one metre.

EXPOSED PERSON:

Any person that is found wholly or partly in a dangerous area.

CRITICAL AREA:

The critical area is that between the tractor and the equipment (PTO drive shaft area).

ZERO ENERGY STATE:

The "Zero Energy State" is defined as the state in which the Tiller is to be set before performing any cleaning, lubrication and maintenance operation.

The operator must carry out the following to set the Tiller to the "Zero Energy State":

- Place the Tiller on flat, non-yielding ground;
- Disable the power take-off;
- Apply the tractor parking brake;
- Switch off the tractor, remove the key and store it;
- Disconnect the PTO drive shaft from the tractor's PTO;
- Put the outrigger in the stop position;
- Disconnect the 3-point hitch.

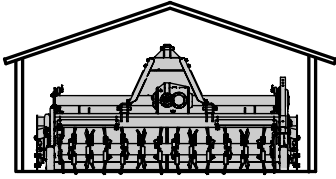

2.4 CONVENTIONAL SYMBOLS

In consulting this operation and maintenance manual and on the Equipment itself a number of symbols are used whose meaning is illustrated below and on the following pages.



RECOMMENDATION:

It refers to a working method implemented in the field, knowing well that each operator will then develop their own way of working.



NOTE:

Draws the attention of staff to information considered to be of high importance.



WARNING:

Draws the attention of staff to information, which, if not respected may cause slight injury to people or damage to the machine.



CAUTION HAZARD:

Informs the staff assigned that the operation described has the risk of physical injury if not performed with respect to the Safety Standards.



MACHINE OPERATOR OR DRIVER:

Identifies the qualified staff, i.e. with specific skills, as the operations are completely manual. Therefore, the preparation and sensitivity of the machine operator are referred to in order to obtain the best qualitative results. The operator is therefore strictly forbidden from performing tasks that should be performed by the maintenance technician.



MECHANICAL MAINTENANCE TECHNICIAN:

Qualified technician who works on mechanical components to carry out all the necessary adjustments, maintenance operations and repairs.



NON-ROUTINE INTERVENTIONS:

Any maintenance interventions highlighted by the symbol on the side must be requested to the Manufacturer or directly to authorized service centres.



PERSONAL PROTECTIVE EQUIPMENT (P.P.E.):

If any of these symbols are present on the side panel, suitable personal protective equipment must be worn by the operator as the risk of accident is implicit.

2.5 OPERATOR REQUIREMENTS

- The machine must be used by a single operator driving the tractor.
- The machine must only be used by authorised personnel, educated and properly trained. The operator, in addition to having read and understood the instructions contained in this manual, must have gained a sufficient

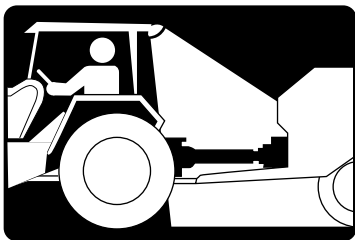

preparation on the proper use of the machine and must be in possession of a driving license. We remind the operator to contact the retailer or the manufacturer if they are unsure about the use of the machine and the interpretation of this manual.

- Do not use the machine if you are tired, ill or under the effects of alcohol, medicines or drugs.
- When driving the tractor, the operator must manage Tiller operation using the hydraulic controls available on the control console of the tractor.

2.6 CLOTHING AND PPE

Staff must use the safety supplies and PPE during use and maintenance of the vehicle.

The correct clothing to be worn during maintenance operations and use of the Tiller is:

- Gloves;
- Accident-prevention shoes or boots with iron toe-cap;
- Protective goggles;
- Overalls with elasticated wrists, ankles and waist.

Furthermore:

- Given that the machine can generate emissions of dust during working, if the tractor does not have a closed cab, the operator must wear an anti-dust mask (especially on dry and dusty land);
- In the event that the tractor is not equipped with a soundproof cab, the operator must wear protective headphones (especially on stony ground);
- The operator assigned to operate the machine is advised to avoid wearing items of clothing that can cause entanglement (scarves, belts, wide sleeves, etc.).

2.7 SAFE USE OF THE MACHINE

- The machine is usually used during the day. If night use is exceptionally required or in conditions of reduced visibility, the tractor's lighting system or any auxiliary lighting system must be used.
- Carefully check the machine before each use.
- Check the tightness of all screws every day (check the tightening torque table). If necessary, tighten them and also control the metal structures and repair them if necessary.
- Make sure that the snap hooks of the PTO drive shaft guard retaining chains are engaged to the appropriate slots so that the plastic guard remains fixed and does not rotate with the shaft itself.
- Before leaving the tractor, and before any maintenance operations, engage the parking brake, stop the engine, remove the ignition key from the dashboard and keep it safe.
- When the machine is in operation, the blades are rotating rapidly: remain at a safe distance to prevent accidental contact with moving utensils or from being hit by any projected objects.

WARNING!

It is absolutely forbidden to tamper with the equipment for any reason. Any arbitrary modification made to this machine exempts SICMA from any responsibility for damages or injuries caused to operators, third parties and property and will result in invalidation of the warranty.

2.8 INTENDED USE

The RD Tiller has been designed expressly to work land and has been developed with the sole purpose of loosening, turning and oxygenating the land in order to prepare it for sowing.

It has been constructed to be combined with tractors of adequate size, capable of withstanding their weight, equipped with a hydraulic lift, with universal three-point coupling and rear power take-off for the operation of the tiller via a PTO drive shaft coupling.

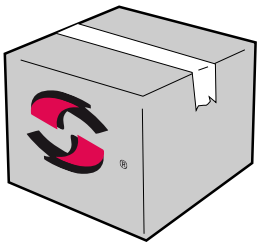

INJURY HAZARD!

Given the particular stress to which the equipment is subjected, if it is necessary to replace certain parts of the components, request only original spare parts.

WARNING!

The use of non-original spare parts exempts SICMA from any responsibility for damage or injuries caused to operators, third parties and property and causes immediate forfeiture of the warranty.

USE ENVIRONMENT

The Tiller works:

- In open fields, on land that is non friable, not excessively stony and with a maximum slope of 3°;
- In environments with a temperature from 0° - 50°C.

IMPROPER USE

Any use different to that declared is to be considered improper.

REASONABLY PREDICTABLE INCORRECT USE

The operator may sometimes use the Tiller incorrectly: below are some examples of what should be avoided.

The operator must not:

- Couple the Tiller to vehicles of unsuitable power or weight.
- Connect the Tiller to a PTO drive shaft with unsuitable power.
- Work in reverse.
- Assemble the Tiller without securing the shock absorbing tie-rods of the three-point hitch of the tractor's lifter.
- Lift the Equipment when the power take-off is rotating.
- Traverse bends or reversals with the Tiller beneath the ground.
- Perform makeshift repairs in order to complete the work.
- Use the Tiller to carry and/or lift persons, animals or objects.
- Work on land with slopes greater than 3°.

2.9 SAFETY DEVICES

Before using the machine, make sure that all safety devices are properly in place and in good condition. If there are failures or damage to the guards, replace them immediately.

Do not tamper with or bypass the safety devices for any reason. After every cleaning and maintenance intervention, all of the safety devices must be restored and/or all protection housings closed. Also verify that there are no tools, rags or other materials inside the transmission compartments.

2.10 POSITION AND MEANING OF THE PICTOGRAMS







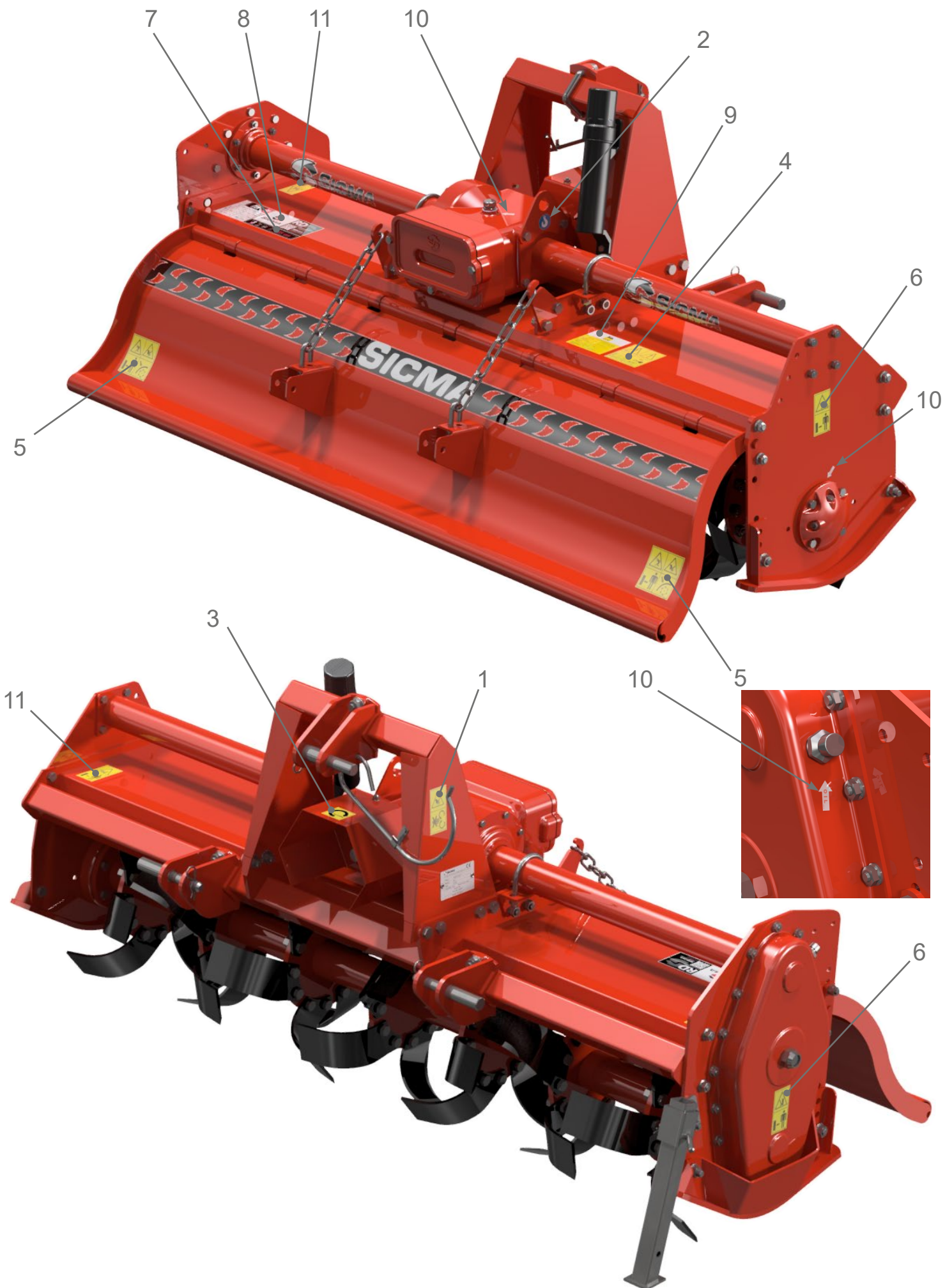

The signs affixed to the machine provide a series of important indications: their observance safeguards the physical safety of the operators and guarantees the optimal effectiveness of the equipment.









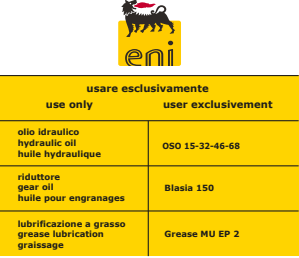





Ensure therefore that the safety pictograms are in good condition and, if they are damaged, replace them with other original ones by relocating them in their place of origin.

Make a request to SICMA or your nearest dealer quoting the reference codes shown on the following pages.

LOCATION OF SAFETY PICTOGRAMS



REF.	STICKER	DESCRIPTION	CODE
1		LIMB INJURY HAZARD Stay clear of rotating PTO.	4781013 Qt. 1
2		HOOKING POINT Fixing point for lifting the machine.	4781031 Qt. 1
3		PTO rpm Use of a 1000 rpm power take-off.	4781010 Qt. 1
4		CAUTION Read all instructions and safety rules carefully before using the machine. Switch off the engine and remove the key before carrying out maintenance or repairs.	4781029 Qt. 1
5		EJECTED OBJECTS Keep a safe distance from the machine. Risk of injury to the hands: do not open or remove the safety guards while the machine is in motion.	4781019 Qt. 2
6		LIMB INJURY HAZARD Keep a safe distance from the machine when it is working.	4781012 Qt. 2
7		WIDTH INFO Width of the machine in cm.	000-110; 000-120; 000-135; 000-150; 000-160; 000-185; 000-210. Qt. 1
8		RD MACHINE STICKER Machine model.	4782601 Qt. 1
9		USE ENI LUBRICANTS ONLY For the hydraulic system: OSO 15-32-46-68 oil; For the gear reducer: Blasia 150 oil; For greasing: GREASE MU EP 2.	4781099 Qt. 1

10		OIL Oil filling point	4781008 Qt. 3																						
11		ROTATING PARTS Danger of injury to the feet, keep a safe distance from the machine when it is working.	4781011 Qt. 2																						
12	<table border="1" data-bbox="695 371 975 645"> <thead> <tr> <th></th> <th>PTO</th> <th>SPEED</th> <th>ROTOR</th> <th>GEARBOX</th> </tr> </thead> <tbody> <tr> <td rowspan="4">540 rpm</td> <td>1</td> <td>18</td> <td></td> <td>15 180</td> </tr> <tr> <td>2</td> <td>17</td> <td></td> <td>203 203</td> </tr> <tr> <td>3</td> <td>16</td> <td></td> <td>17 230</td> </tr> <tr> <td>4</td> <td>15</td> <td></td> <td>18 259</td> </tr> </tbody> </table>		PTO	SPEED	ROTOR	GEARBOX	540 rpm	1	18		15 180	2	17		203 203	3	16		17 230	4	15		18 259	GEARBOX INFO (rotor revolutions) <ul style="list-style-type: none"> • 1st = 180 rpm • 2nd = 203 rpm (default) • 3rd = 230 rpm • 4th = 259 rpm 	4782602 Qt. 1
	PTO	SPEED	ROTOR	GEARBOX																					
540 rpm	1	18		15 180																					
	2	17		203 203																					
	3	16		17 230																					
	4	15		18 259																					

3. UNLOADING AND UNPACKING THE TILLER



CRUSHING HAZARD!

Qualified staff that have read and understood the safety prescriptions must unload the Tiller from the lorry and handle the Equipment in the work place. These manoeuvres should be supervised by an experienced manager. In all cases, make sure that there are no people, animals or objects in the unloading area.

The Tiller is normally transported on a lorry, sometimes without packaging, sometimes protected by heat shrinkable film and other times in wooden crates.



NOTE!

Before unloading the equipment from the truck, read this entire sequence in order to be prepared for all events.



OVERTURNING AND CRUSHING HAZARD!

Tiller unloading must be carried out slowly and with the utmost care in an area completely free from persons or objects.



RISK OF THE TILLER FALLING FROM THE TRUCK!

Recall that no matter how stable the equipment, during subsequent transportation procedures, it must ALWAYS:

- Be well secured to the lorry, paying attention not to crush any hydraulic pipes;
- Be placed in the middle of the lorry and not near the edges, in order to avoid losing the Tiller on the road in case it overturns due to turns or broken road, with very serious consequences.

3.1 TILLER PROTECTED BY HEAT-SHRINKABLE FILM

Release the Tiller from any fixing devices used to fasten it to the means of transport.

Before lifting using the lorry's lifting arm, check that all locking mechanisms (snap hooks, shackles, etc.) and the ropes/chains used are in good condition; each must be able to lift the weight of the machine (see weight in sec. 4 "Technical specifications").

After harnessing the Tiller, lift it a few centimetres to check the correct distribution of weights: in case of imbalance, reposition the Tiller on the platform, correctly adjust the harness and the length of the ropes/chains and repeat the procedure.

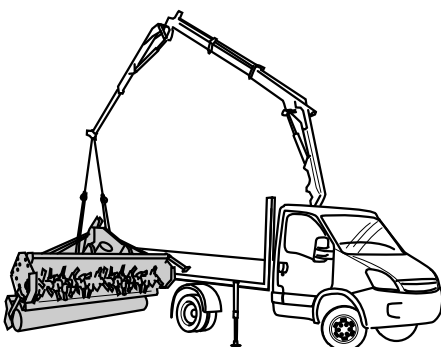

Lift the Tiller from the deck of the means of transport to a height of approximately 30 cm, unless obstacles are present, so that it does not swing. Position the Tiller on the ground in proximity of the tractor.

Remove the ropes and the chains from the Tiller.

Once on the ground, unpack the equipment as described below.

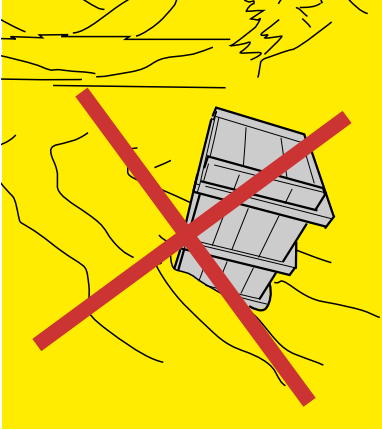

CUTTING HAZARD!

In the event that the Tiller arrives wrapped in a protective film, remove it with the aid of a cutter wearing anti-cut gloves; take care not to injure yourself and not damage the Tiller itself.



CONTAMINATION HAZARD!

Do not dispose of the packaging in the environment, but contact specialist collection agencies. Check the transport document or packing list supplied and, if necessary, act as described in section 1.5 "General notes on delivery".

3.2 TILLER PACKAGED IN WOODEN BOX

If the Tiller is contained inside a wooden box, use a forklift of adequate capacity for unloading (to ascertain the weight of the Tiller, refer to the technical specifications table in sec. 4).

Release the Tiller from any fixing devices used to fasten it to the means of transport.

Insert the forklift forks into the appropriate slots on the platform.

Lift the box from the walking surface of the means of transport by a maximum height of 30 cm, unless hindered by obstacles.

Place the crate on the ground in the vicinity of the tractor.

With a suitable tool and wearing protective gloves, remove the wooden crate.

Harness the Tiller with ropes and/or chains of adequate capacity, lift the equipment by a few centimetres and remove the lower part of the wooden crate. Place the Tiller on the ground and approach the tractor in reverse so that the tractor PTO is positioned frontally to the one of the Tiller.

Couple the Tiller to the tractor using the 3-point hitch according to section 5.1.

Check the transport document or packing list supplied and, if necessary, act as described in section 1.5 "General notes on delivery".



4. TECHNICAL SPECIFICATIONS

The table below outlines the technical specifications of the RD Tiller.

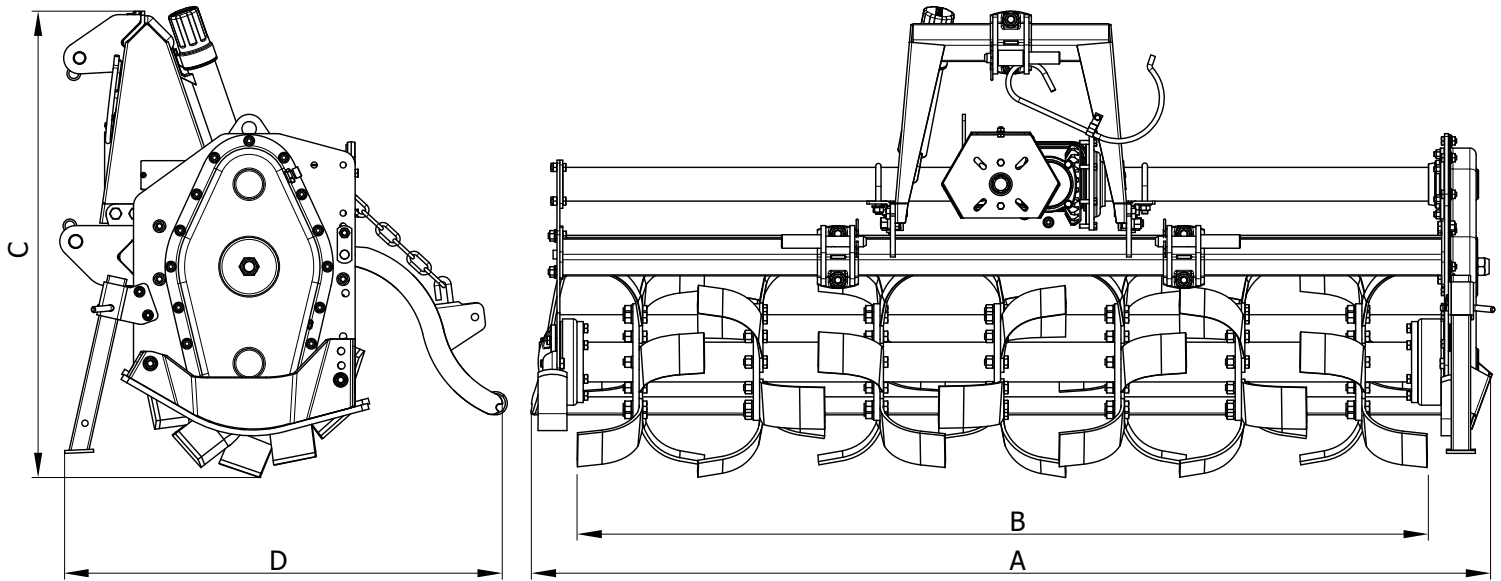

			Machine type						
			RD/110	RD/120	RD/135	RD/150	RD/160	RD/185	RD/210
Tiller	Overall width (A)	mm	1254	1354	1490	1636	1740	1990	2240
	Working width (B)	mm	1100	1200	1336	1482	1586	1836	2086
	Height (C)	mm	969	969	969	969	969	969	969
	Side clearance (D)	mm	771	771	771	771	771	771	771
	Work depth	mm	129	129	129	129	129	129	129
	WEIGHT (standard)	kg	325	340	360	380	395	430	465
		lbs	717	750	794	838	871	948	
Rotor	Number of rotor revolutions (no gearbox)	Revs/min	216						
	Rotor RPM (gearbox)	Revs/min	1st = 180 2nd = 203 (default) 3rd = 230 4th = 259						
	Rotor pipe diameter	mm	82.5						
	Rotor pipe thickness	mm	8						
	Rotor work diameter	mm	470						
	Number of hoes	4 hoes/flange		16	20	20	24	24	28
6 hoes/flange			24	30	30	36	36	42	48
Tractor requisites	Minimum tractor power	CV	35	35	35	45	45	45	55
	Tractor hitch category	cat	1st-2nd	1st-2nd	1st-2nd	1st-2nd	1st-2nd	1st-2nd	1st-2nd
	PTO speed	rpm	540	540	540	540	540	540	540
Noise level (no-load noise levels):	Sound pressure level (dB):		87.2			Noise level (no-load noise levels):	Sound pressure level (dB):	87.2	
	Noise power level (dB):		99.8				Noise power level (dB):	99.8	



5. START-UP

INJURY HAZARD!

Only qualified operators who have read and understood the safety instructions can perform the operations described below. Moreover, they must check that there are no persons, animals and properly exposed in the area where the connection is made to the tractor.

The operator and any assistants must have PPE (Personal Protective Equipment) available and use it as required.

The Tiller can only be moved and used if connected to the tractor; strictly follow the instructions given below, in the order provided, to couple it to the tractor:

- CONNECTING THE TILLER TO THE TRACTOR (3-point hitch);
- CONNECTING THE PTO DRIVE SHAFT (power take-off).

5.1 CONNECTING THE TILLER TO THE TRACTOR

To connect the Tiller to the tractor, the operator must slowly approach the tractor in reverse to the Tiller and position themselves so that the arms of the tractor lifter are aligned with the two lower pins of the Tiller.

Once in position, engage the hand brake, switch the engine off, remove the key and keep it and climb down from the tractor.

Make sure that the PTO drive shaft protection is intact; if not, repair or replace.

To hook the machine to the tractor, proceed as follows:

- Remove the cotter "A" of the pins "B" and remove the pins;
- Slowly retract with the tractor until the joint of the lifting arm "C" of the tractor matches the third lower point "D" of the Tiller.
- Turn off the engine, apply the parking brake, remove the key and keep it on your person;
- Insert the pins "B" into the holes of the third lower point of the Tiller and into the hole of the joints of the tractor arms;
- Reinsert the relevant cotters;
- Lock the shock absorbing tie-rods of the lifting arms of the tractor to prevent the machine from swinging laterally, compromising the transverse stability of the tractor/Tiller unit;
- Remove the cotter "E" of the pin "F" from the third upper point of the Tiller and remove the pin;
- Release the tie-rod "G" of the upper third point of the tractor and insert it into the upper third point "H" of the Tiller;
- Reinsert the pin "F" and its cotter "E" into the upper third point of the Tiller and in the joint of the tie-rod "G" of the tractor;
- Adjust the length of the tie-rod so that the upper part of the frame is parallel to the ground.



It is always good practice to make sure that the tiller PTO axis is parallel to the ground thus reducing stresses to a minimum on the power take-off and extending the working life of the Tiller.

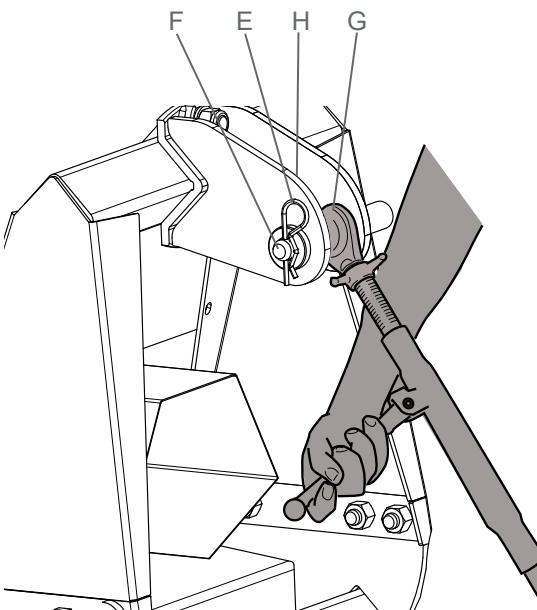
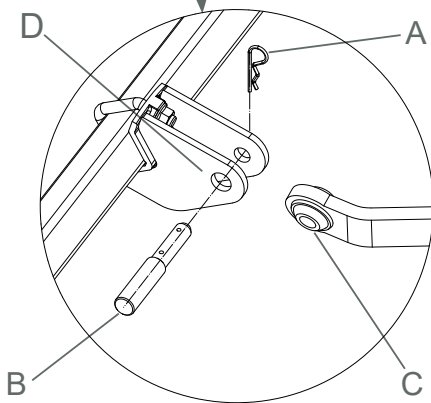
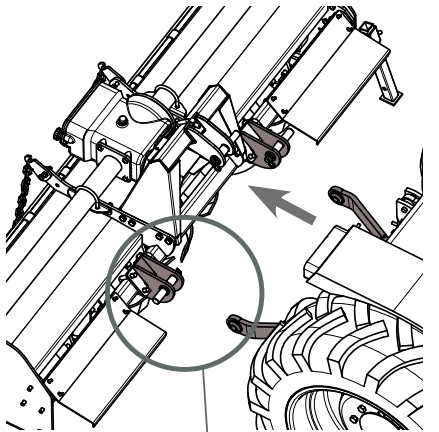



5.2 PTO DRIVE SHAFT COUPLING

Before installing the PTO drive shaft, the operator must:

- Read and understand the manual of the PTO drive shaft and of the tractor;
- Check that the number of revs. and the direction of rotation of the tractor PTO correspond to those of the Tiller. If the direction of rotation of the Tiller does not correspond to that of the tractor, contact the dealer or an authorised workshop;
- Verify that the minimum and maximum length of the PTO drive shaft are those required by the tiller-tractor coupling. Remember that when at maximum extension, the pipes must overlap at least 1/3 of the length of the internal pipe. Moreover, in the maximum closure position of the pipes, the minimum play allowed of the plastic protections must be at least 2 cm. in order to prevent damage to the protections and the reducer. If this is not the case, it must be shortened by cutting it as much as necessary; refer to the PTO drive shaft use and maintenance manual or contact your authorised dealer.
- Check that the PTO drive shaft protection is 100% intact, otherwise proceed accordingly by consulting the relevant user manual.

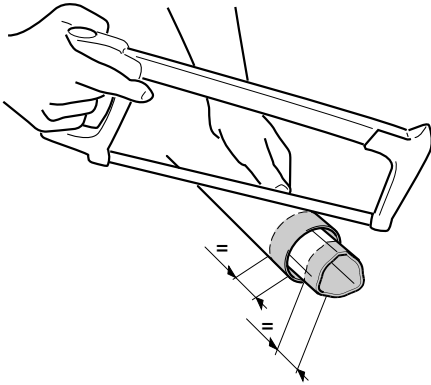
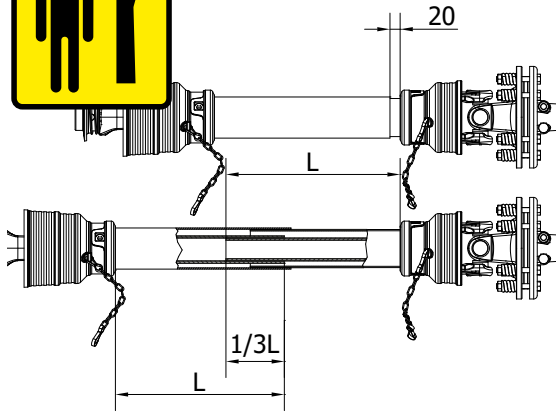

To connect the PTO drive shaft, the operator must:

- With engine off, loosen the 3 screws "A" that secure the Tiller PTO metal guard "B" and remove it.
- Align the PTO shaft in the correct direction, ensuring that the safety device "C" faces the side of the equipment; in each case, refer to the tractor design stamped on the outer tube of the PTO shaft guard.
- Insert the hub of the safety device "C" on the power take-off of the Tiller;
- When the safety device is fully inserted, tighten the two bolts of the safety device attachment "C";
- Replace the guard "B" on the power take-off of the Tiller and tighten the three screws "A";
- Insert the opposite hub of the PTO shaft into the tractor's PTO while holding the safety pin down as far as it will go; release the pin and drive the PTO shaft backwards until the pin engages with an audible "click" in its seat;
- Then hook the snap hooks of the retaining chains "D" of the PTO shaft guard into their respective seats to prevent it from rotating during use.

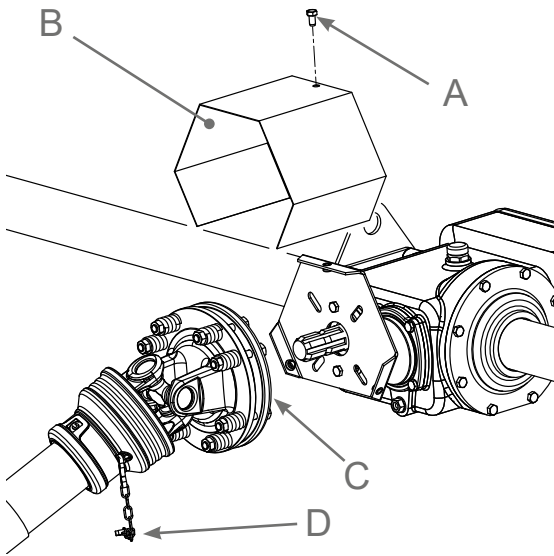

5.3 CHECK THE STABILITY OF THE TRACTOR-TILLER COMPLEX

Tiller weight changes the stability of the tractor-Tiller complex, influencing steering and braking capability. Therefore proceed at a moderate speed. In particular, it should be noted that the front axle must always be carrying a load of at least 20% of the weight of the tractor-Tiller unit.

Check the lifting capacity and stability of the tractor using the following formula and, if necessary, before applying the front weights.

$$M \times (S1+S2) \leq 0.2 T \times i + Z \times (d+i)$$

$$M \leq 0.3T$$

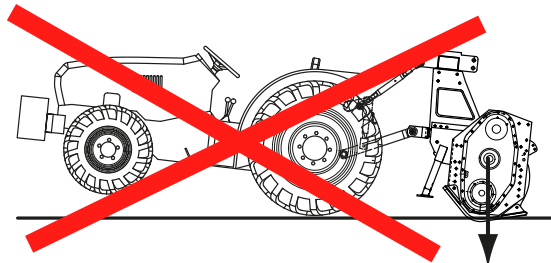

i	= wheelbase
d	= distance between the front axis and the ballasts
S1	= distance between centre of the rear axle and centre of the lower connection points
S2	= distance between the centre of the lower hitch points and the barycentre of the tiller
T	= weight of the tractor + 75Kg (operator)
Z	= mass of the ballast
M	= the mass of the machine

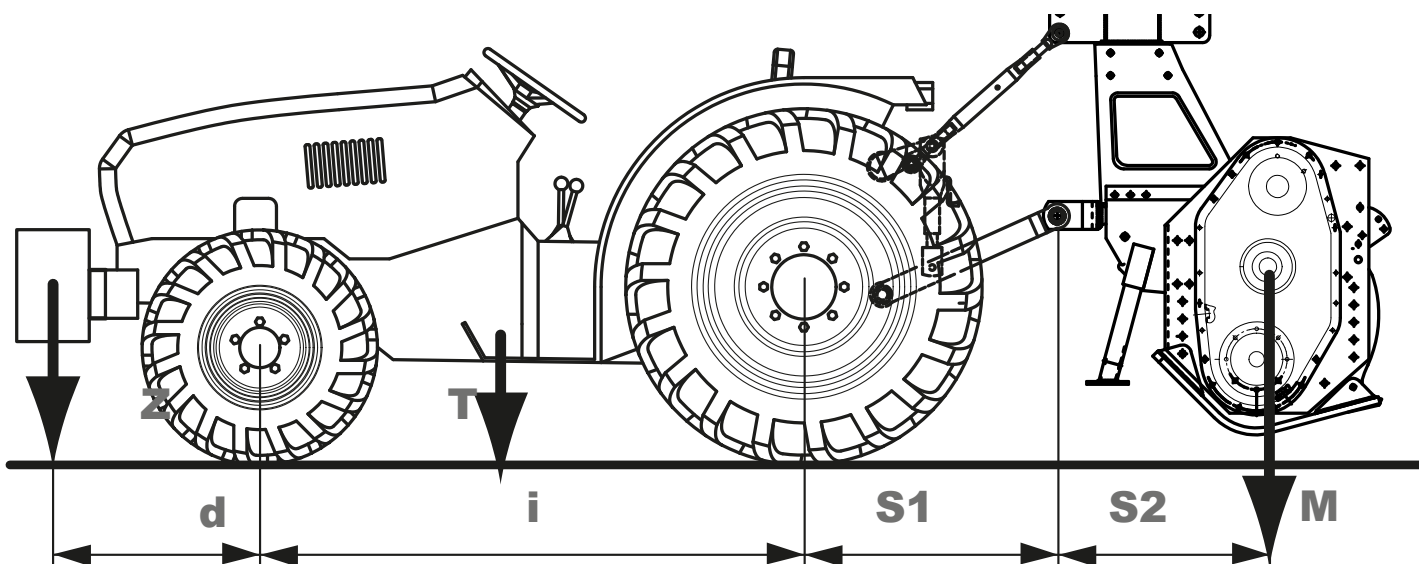

5.4 ROAD TRANSPORT

Articles 61 and 104 of the Highway Code of the Italian State prescribe that the maximum width of vehicles on roads is 2.55 metres. As a consequence, all measurements of the RD available are authorised for road transport, in compliance with the other prescriptions of the Highway Code.

If the Country of reference is not Italy, follow the Highway Code Standards of the country of use.

6. ADJUSTMENTS

6.1 ROTOR GEARBOX

At the time of purchase, you can choose between two configurations of the RD Tiller: with gearbox and without gearbox.

If the Tiller is fitted with a gearbox, swap the positions of the gears in the gearbox in order to change the rotation speed of the rotor.



BURN HAZARD!

Before touching the drive unit, wait until it has cooled sufficiently to avoid burns to hands. Wear protective gloves.

To change the rotor speed, the operator must:

- With the engine off and the drive shaft disconnected, drain and collect the oil from the gearbox as indicated in sec. 8.1;
- Choose the number of revolutions of the most desired rotor by consulting the table below;
- Unscrew the 3 screws "A" of the gear cover "B" which contains the 2 gears "C" and "D" to change the speeds;
- Reverse the 2 gears "E" and "F" splined to the primary and secondary shafts or replace them with spares;
- Replace the gear cover and tighten the 3 screws "A";
- Fill the oil box with the oil previously collected using the hole in cap "G".

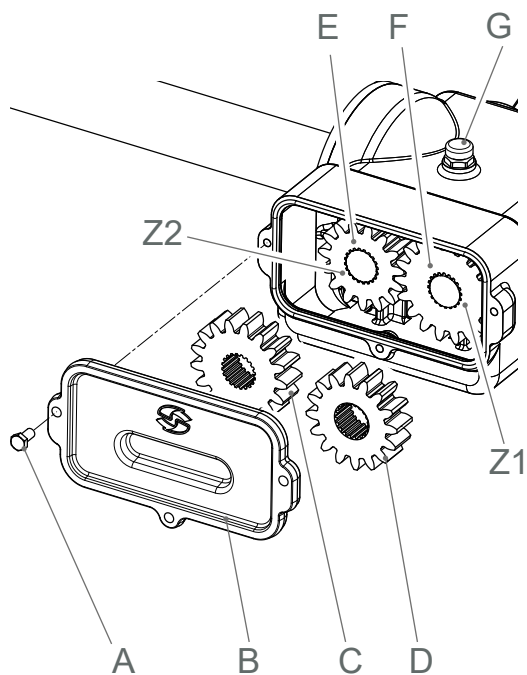

rpm	Z1	Z2	Rotor rpm
540	15	18	180
	16	17	203
	17	16	230
	18	15	259

standard configuration

6.2 CLUTCH ADJUSTMENT

The clutch, which is equipped with the coupling supplied with the Tiller, is sized to transmit the correct power to the equipment and it is calibrated and preset at the factory; it is, therefore, inadvisable to modify this value in order to prevent damage to the Tiller or the PTO drive shaft.

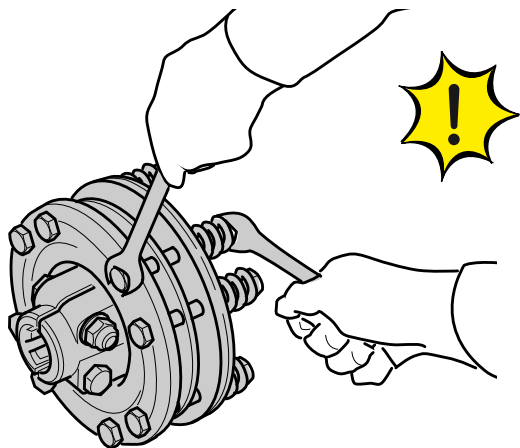

WARNING!

SICMA shall not be liable for damage deriving from incorrect modification of the clutch calibration.

However, adjustment becomes necessary if the clutch is triggered too frequently, while operating on easily machinable soils, i.e. neither hard nor compact: this means that the clutch calibration is too low.

The clutch associated to the PTO Drive Shaft is an FD1 EUROCARDAN, with standard calibration of 800Nm. If it is necessary to increase the calibration of the clutch, tighten the spring clamping nuts by 1/3 turn, thus obtaining an increase in transmissible torque by approximately 160 Nm. Unscrew the nuts if this value needs to be reduced.

If you do not plan to use the equipment for a long period, it is advisable, after noting the height of the springs measured with a precision gauge, to unscrew the nuts compressing them to prevent the discs from “sticking” to each other and causing them to seize.

When reusing the safety device, restore the original calibration by adjusting the heights of the springs as follows:

- Screw the nuts by hand until the clearances of the springs are zero;
- Screw a nut precisely counting the number of revolutions necessary to reach the original height of the compressed spring;
- Screw all the other bolts with the same number of revolutions used for the first.



CAUTION!

Ensure that the height of the compressed springs is the same for all of them to prevent clutch malfunction.



WARNING!

Do not pack the clutch springs together as the equipment would be unprotected from overloads.

6.3 WORK HEIGHT ADJUSTMENT

The work height can be modified by operating on the position of the skids or any rear roller (optional).



CRUSHING HAZARD!

There are 2 adjustment options for skids, as well as the holes for locking them. To modify the position of the skids, after having lifted the tiller and having positioned it on supports, proceed as follows:

- Loosen the bolt “A”;
- Unscrew and remove the bolt “B”;
- Rotate the skid until it reaches the desired position;
- Replace the bolt “B”;
- Tighten both bolts “A” and “B”;
- Proceed with the same procedure on the opposite skid, making sure that both are adjusted to the same height.

Finally, check that the Tiller is parallel to the ground and, if necessary, adjust its planarity by using the lever on the tie-rod of the 3rd upper point (see sec. 5.1).

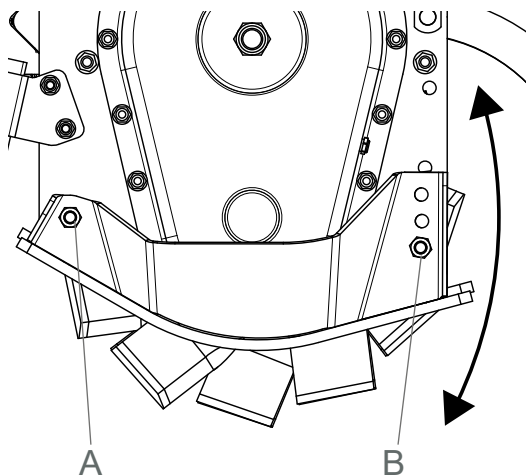

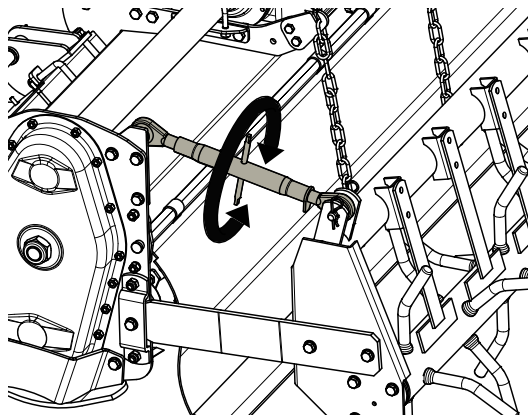

If the machine is fitted with a rear roller (optional), the tilling depth depends on the vertical position of the roller itself, and the skids only serve to protect the plates and the drive casing.

To adjust the roller, rotate the lever on the two side tie-rods as shown in the figure.

To increase the tilling depth, shorten the length of the tie-rods, and vice versa to decrease it.

Then ensure that the length of the two tie-rods is the same.

Finally, check that the Tiller is parallel to the ground and, if necessary, adjust its planarity by using the lever on the tie-rod of the 3rd upper point (see sec. 5.1).

6.4 REAR BONNET ADJUSTMENT

If the Tiller is equipped with a rear bonnet supported by chains, it is possible to adjust its inclination simply by shortening or lengthening the stretched chain section.



HAND SHEARING HAZARD!

When adjusting the rear cover, never grasp it by its sides, only by its lower edge. Wear protective gloves.

If the Tiller is equipped with a cover with spring adjuster, its inclination can be adjusted by unscrewing or screwing the nut "A" located at the upper end of the adjuster.

Screwing the nuts, the bonnet lifts, vice versa if unscrewed.

Finally, check that the two bonnet adjusters are adjusted in the same way.

7. USE

The Tiller is interchangeable equipment (Machinery Directive art. 1 paragraph b) and to work it must be connected to a tractor; it is from the tractor itself that all its controls are managed.

The operator must refer to the tractor user's manual in order to ensure proper functioning of the Tiller.

Once all checks and adjustments have been performed, with the tractor connected to the Tiller (via the 3-point hitch with the PTO drive shaft disconnected), start the tractor and go to the working area, keeping the Tiller raised above the ground so that the blades do not touch the ground (at least 20 cm).



WARNING!

Before using the Tiller make sure that no persons or animals are within the range of action of the machine.

Make sure all equipment guards are present and efficient.

The machine must only be used by one operator positioned inside the tractor driving cab.



NOTE!

Before using the Tiller, read the following procedures, in order to be prepared in time for any situation.

Upon arrival at the work place, the operator must:

- Engage the parking brake;
- Switch the engine off;
- Remove the ignition key and keep it on themselves;
- Connect the drive shaft to the tractor PTO (section 5.2).
- Start the tractor's engine;
- Release the parking brake;

- With the Tiller raised, start the PTO, activate the descent of the Tiller and allow the rotating tools to penetrate the ground;

- Start the tractor and proceed at a maximum speed of 6 km/h;

Only the technical sensitivity of the operator, the result of his/her experience, allows to maintain the right rotation speed of the tractor engine based on the specific use.

In case of soil that is difficult to work (hard, stony, etc.), reduce the speed by approx. 2 km/h;



RECOMMENDATION!

In cold weather, it is a good idea to start the equipment at low speed to allow the Tiller to reach the right operating temperature.

Move for a short distance with the tiller working and check the quality of the work. If it does not satisfy you, repeat and review the machine adjustment operations (section 6).



LIMB INJURY HAZARD!

Never place hands and feet near to the tools-holder rotor when it is rotating (or when not in Zero Energy State).



RISK OF PERSONAL INJURY!

During operation, the machine can project material at high speed: make sure that there are no animals or people exposed to the rear side of the Tiller.

In the operations involving sudden steering, turning and moving in reverse, disengage the power take-off and lift the tiller slightly from the ground, in order to avoid damaging its frame.

Once the work has been completed, the operator must:

- Engage the parking brake;
- Turn off the engine, remove the start key and keep it;
- Disconnect the drive shaft from the tractor PTO and position it on the dedicated hook;
- Restart the tractor and, ensuring that there are no exposed persons or animals, move to the storage place.

Having reached the depot, the operator must:

- Engage the parking brake;
- Turn off the engine, remove the start key and keep it;
- Clean the Tiller (see chap. 9);
- Check that there are no oil leaks and, if any, fix them;
- Check the condition of the equipment and replace any worn parts (see Chap. 10).



NOTE

Should any faults arise while using the Tiller, consult section 14.2 "Troubleshooting".

8. STOPS



INJURY HAZARD TO OPERATORS AND DAMAGE TO THE STRUCTURE!

Only qualified operators that have read and fully understood the safety prescriptions (chap. 2) can perform the operations described below.

Moreover, they must check that there are no exposed people, animals and objects in the dangerous area.

The equipment must be stopped in the following ways:

- Temporary stop;
- Day end stop;
- Long downtime period;
- Emergency stop.

TEMPORARY STOP

To stop the Tiller temporarily, just deactivate the rotation of the tractor PTO by activating the control on the tractor's control console.

DAY END STOP

- Engage the parking brake;
- Turn off the engine, remove the start key and keep it;
- Clean the Tiller (see chap. 9);
- Check that there are no oil leaks and, if any, fix them;
- Check the condition of the equipment and replace any worn or damaged parts (see Chap. 10).

LONG DOWNTIME PERIODS

- Engage the parking brake;
- Adjust the outrigger of the Tiller, so as to stabilise it correctly;
- Place the Tiller on the ground;
- Engage the parking brake;
- Turn off the engine, remove the start key and keep it;
- Disconnect the drive shaft and place it on the support hook;
- Release the Tiller from the tractor using the 3-point hitch pins;
- Restart the tractor and move away carefully;
- Lubricate all Tiller parts with an anti-oxidant product.

The Tiller must be parked on a flat, compact surface within a protected area, so as to prevent access of unauthorised persons.

EMERGENCY STOP

The emergency stop procedure should be carried out in the event of a hazard or malfunction and consists of:

- Turn off the PTO to stop the Tiller and stop the tractor;
- Engage the parking brake;
- Turn off the engine, remove the start key and keep it;
- Identify the cause of the emergency stop and, if necessary, consult the "Troubleshooting" table (section 14.2).

Then decide whether:

- It is necessary to put the equipment in Zero Energy State;
- Technical support must be called;
- It can be repaired.

Once the cause of the emergency stop has been eliminated, restart the Equipment and finish the work.

9. CLEANING



INJURY HAZARD TO OPERATORS AND DAMAGE TO THE STRUCTURE!

Only qualified operators that have read and fully understood the safety prescriptions (chap. 2) can perform the operations described below. Moreover, these must check that there are no exposed people and animals in the dangerous area.



INJURY HAZARD!

During cleaning, use all the necessary PPE such as cut-resistant gloves and safety shoes, and be very careful not to touch the sharp parts of the hoes with bare hands.



The operator must carry out cleaning operations on a non-yielding, flat surface, only after having placed the Tiller in a Zero Energy State (section 2.3).

If compressed air is used to clean the machine, appropriate goggles are needed.

At the end of every work day, it is advisable to wash the Tiller with a pressure washer, especially the following parts:

- Chassis surface;
- Hoes;
- Mast;
- Rear hoods;
- Rotor.

To clean the rotor compartment, lift the rear covers.

After washing, dry with compressed air and protect the non-coated metal parts by applying a layer of lubricant to prevent oxidation.

10. ROUTINE MAINTENANCE



INJURY HAZARD TO OPERATORS AND DAMAGE TO THE STRUCTURE!

Only qualified operators that have read and fully understood the safety prescriptions (chap. 2) can perform the operations described below.

Moreover, they must check that there are no exposed persons, animals or objects in the hazardous area.

The operator must know and strictly follow the instructions described and must have set the Tiller to Zero Energy State.



WARNING!

The periodic checks and the maintenance operations described in this chapter must be performed at the times and in the ways established and are the operator's responsibility.

Failure to comply with maintenance standards and schedule compromises the proper operation of the machine and its service life, and voids the warranty.



For all other maintenance, see sec. 14.2 ("Troubleshooting") or contact the Manufacturer or its After-sales centres.

Given the complexity of the Equipment, repairs, modifications, special maintenance other than those listed below must NOT take place without consulting the Manufacturer or its service centre. Depending on the circumstances, these will provide authorisation and all necessary instructions, or alternatively they will recommend an intervention by one of their own technicians.

Compliance with these precautions protects the operators and keeps the equipment intact.



OVERTURNING HAZARD!

Ensure the stability of the equipment before attempting any maintenance.



The maintenance technician and any aids must have PPE available and wear them as required.

Do not perform repairs whose outcome may be doubtful. Always follow the instructions and, if they are lacking, contact the supplier or expert personnel.



POISONING HAZARD!

Do not leave the tractor engine on inside closed spaces not equipped with ventilation system.

- Avoid prolonged and repeated skin contact with lubricants as they could cause skin disorders or other types of syndromes.
- Do not swallow fuel / lubricants / fluids. In case of accidental contact with eyes rinse thoroughly with tap water.
- Do not weld in closed places or rooms that are not appropriately ventilated.
- Do not weld painted surfaces: first remove the paint layer with suitable products, then wash and allow to dry.

10.1 CONTROL AND REPLACEMENT OF THE OIL IN THE GEARBOX ASSEMBLY

(Fig. 1 gearbox)

(Fig. 2 no gearbox)



BURN HAZARD!

Before touching the upper transmission unit, wait until it has cooled down sufficiently.

CONTAMINATION HAZARD!

Check that there are no oil leaks and, if necessary, fix them immediately. Do not spill oil onto the ground during top-up or replacement.

WARNING!

Correctly recover the used oils and dispose of them at the appropriate collection centres, as, according to current regulations, it must not be released to the environment because it is classified as hazardous waste. It is therefore necessary to contact the "Consorzio Obbligatorio Oli Usati" (www.coou.it; green line **800-863048**). For the other countries, refer to the respective anti-pollution regulations in force.

 usare esclusivamente use only user exclusivemnt	
olio idraulico hydraulic oil huile hydraulique	OSO 15-32-46-68
riduttore gear oil huile pour engranages	Blasia 150
lubrificazione a grasso grease lubrication	Grease MU EP 2

CHECK THE OIL LEVEL

(Every 50 hours)

Gearbox oil level is checked by viewing the mark left by the oil on the dipstick of filler cap "A", which must be between the two reference marks (minimum and maximum).

If it is necessary to add more oil, proceed as follows:

- Remove the oil filler cap "A";
- Top up with AGIP-ENI BLASIA 150 type oil until the level is restored as indicated above;
- Refit and tighten the filler cap "A".

OIL REPLACEMENT

(The first time after the first 50 hours and then every 500 hours)

To change the oil, proceed as follows:

- Place a sufficiently large container below the oil drain "B" (lower part of the casing);
- Unscrew the filler/vent plug "A" and the oil drain plug "B" and wait for the spent oil to drain completely inside the container;
- Replace and tighten the two caps "A" and "B";
- Fill the box with new AGIP-ENI BLASIA 150 type oil until the correct level is restored;
- Dispose of the drained oil in appropriate containers for waste oils

Fig. 1

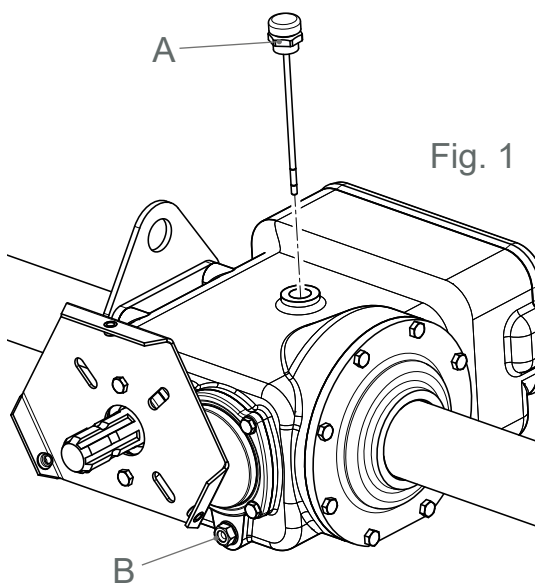
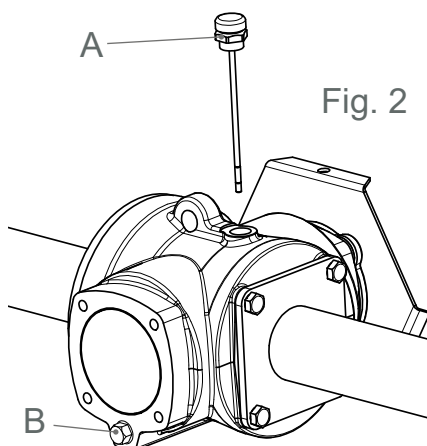

Fig. 2



10.2 CONTROL AND REPLACEMENT OF THE OIL IN THE LATERAL DRIVE SUMP

CHECK THE OIL LEVEL (Every 50 hours)

Check the oil level in the lateral transmission casing by checking that it is visible inside the side cap "C" window.

If top-up is necessary, proceed as follows:

- Remove the oil filler cap "D";
- Top-up with AGIP-ENI BLASIA 150 oil until it is visible inside the cap "C" window;
- Replace and tighten the loading cap "D".

OIL REPLACEMENT

(The first time after the first 50 hours and then every 500 hours)

To change the oil, proceed as follows:

- Disassemble the side skid at the transmission casing by unscrewing the two bolts "E";
- Place a container under the oil drain with cap "G";
- Unscrew and remove the oil filler cap "D" to allow a quick outflow of the oil;
- Unscrew and remove the cap "G" and wait for the spent oil to drain completely;
- Replace and tighten the cap "G";
- Fill the casing with AGIP-ENI BLASIA 150 type oil until the level is restored as indicated above;
- Replace and tighten the cap "D";
- Replace the side skid in the same position by tightening the bolts "E" fully;

10.3 CONTROL AND REPLACEMENT OF THE OIL IN THE EXTERNAL ROTOR LATERAL SUPPORT

CHECK THE OIL LEVEL (Every 50 hours)

The oil level of the lateral rotor support is checked by verifying that the lubricant is visible inside the window of cap "H" located on the support itself.

If top-up is required, proceed as follows:

- Unscrew the oil filler cap "I";
- Top-up with oil type AGIP-ENI BLASIA 150 to restore the level;
- Replace and tighten the filler cap "I".

OIL REPLACEMENT

(The first time after the first 50 hours and then every 500 hours)

To replace the oil proceed as follows:

- Disassemble the side skid at the support by unscrewing the bolts "L";
- Place a container under the support;
- Loosen the four bolts "M" and slightly detach the support from the plate until the oil is free to escape; then wait for the complete outflow;
- Tighten the four previously loosened bolts "M";
- Unscrew and remove the oil cap "I" and top up with TAGIP-ENI BLASIA 150 type oil until the oil level is restored;
- Tighten the cap "I";
- Replace the skid and tighten the bolts "L".

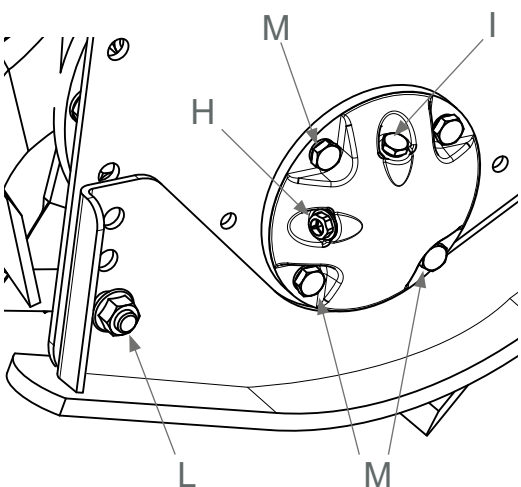
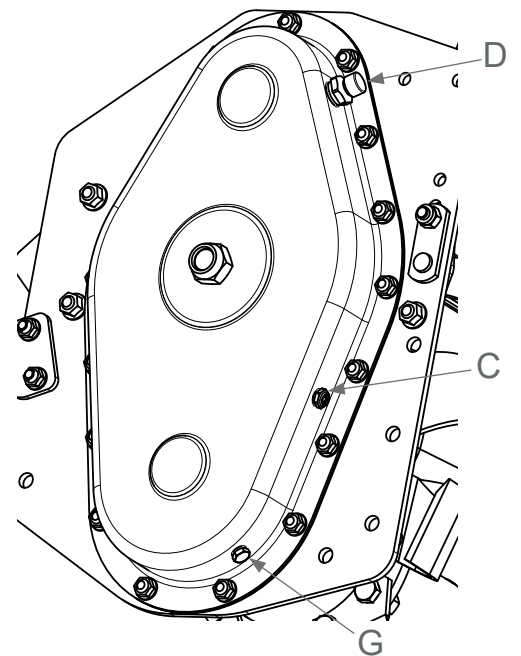
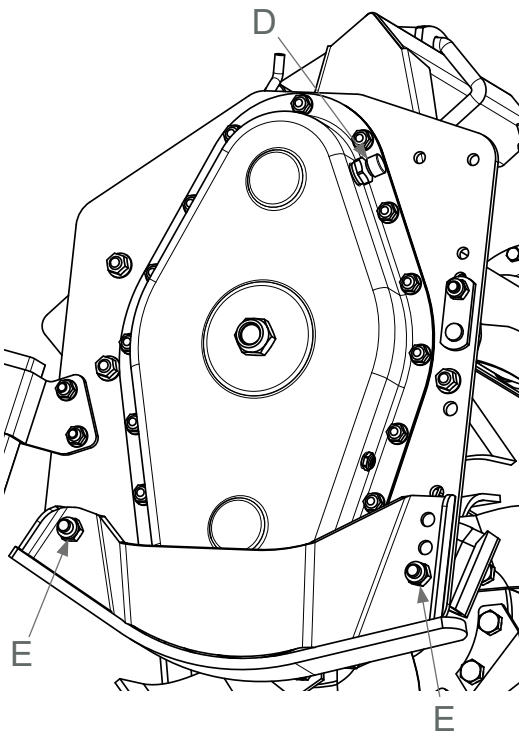

10.4 GREASING



WARNING!

Before injecting lubricating grease, carefully clean the grease nipples to prevent dust or impurities of any kind from mixing with the grease, reducing lubrication efficiency.

For greasing, use the appropriate lubricant pump TYPE HYDRAULIC FORM "A" UNI 7663 and use **AGIP GREASE MU EP 2** grease.

GREASING THE REAR ROLLER SUPPORTS (optional) (Every 8 hours)

The grease points of the rear roller supports must be greased with AGIP GREASE MU EP 2 type grease by injecting it into the nipples located on the side of the support plates.

10.5 HOE REPLACEMENT

Before carrying out the following operations, put on the necessary PPE, especially protective gloves and safety shoes.



CRUSHING HAZARD!

When you replace the tools, NEVER STAND BELOW the rotor with the Tiller raised above the ground; never rely only on the tractor's hydraulic lift tightness: insert mechanical struts or stands between the Tiller and the ground in order to avoid accidental and dangerous lowering of the machine.

VISUAL CHECK OF THE HOES (Every 50 hours)

Visually inspect the wear of the hoe blades: they should be replaced when an increase in power consumption of the tractor due to wear is detected during operation, or when blade size is significantly reduced compared to its initial size.



WARNING!

The Tiller is subject to heavy mechanical stress. Therefore, only the use of original tools guarantees prolonged life of the machine and the utmost safety of the operators.

The use of non-original spare parts exempts SICMA from any responsibility for damage or injuries to operators, third parties and property and causes immediate forfeiture of the warranty.

To purchase original spare parts, see the spare parts section at the web address: www.sicma.it.

REPLACING INDIVIDUAL WORN HOES

(When hoe blades are worn out)

To replace a single hoe blade, proceed as follows:

- Hitch the Tiller to the tractor without the PTO drive shaft;
- Lift the Tiller;
- Stake the Tiller with supports of adequate size and turn off the engine;
- Unscrew and remove the bolts that lock the hoe to be replaced;
- Position the new hoe observing the original position and reinsert the two bolts previously extracted by repositioning screws, washers and nuts also in their original positions;
- Tighten all the flange bolts, respecting the tightening torque shown in the table in section 14.1.

REPLACING ALL HOES

(When hoe blades are worn out)

To replace all hoe blades, proceed as follows:

- Prop up the Tiller as described above;
- Replace one hoe at a time on one of the two end flanges as described in the previous section, replacing all parts (screws, hoe, washers and nuts) in their original positions.
- Once all the hoe blades of the first flange have been replaced, move to the next one and repeat the operations.
- Tighten the bolts, observing the tightening torques in the table in section 14.1.

11. PTO DRIVE SHAFT

For both maintenance and any repairs, proceed as described in the use and maintenance manual by the manufacturer of the installed PTO drive shaft.

12. STORAGE AND WINTERING

If the machine is immobilised for long periods, it must be stored indoors protected from atmospheric agents, if possible, and placed on a flat, compact surface. Before setting it aside, clean the whole machine and lubricate all mechanical parts to protect them from corrosion.

Before putting the machine in long downtime periods, it is advisable to proceed as follows:

- Free the rotor and the tools from tilling residues;
- Thoroughly clean the machine;
- Perform a general visual inspection of the machine to detect any structural damage;
- Check that the original safety pictograms are present in their positions and that they are intact and legible (sec. 2.10);
- Grease all mechanical parts and the fastening pins;

RECOMMENDATION!



If the machine is fitted with a disc clutch device, it is advisable, after noting the height of the compressed springs, to unscrew the screws compressing the springs to prevent the discs from sticking to each other (see sec. 6.2 “Clutch adjustment”).

13. SCRAPPING



In the event of scrapping, the machine must be disposed of in suitable waste disposal sites, in compliance with the law in force.

Before scrapping, separate the plastic or rubber parts. Recover any waste oils and dispose of them at relevant collection centres.

Used oil must be appropriately recovered and must not be dispersed in the environment because according to current regulations it is classified as hazardous waste and as such should be taken to the appropriate collection centres. For the collection of the used oils, it is mandatory to contact the “Consorzio Obbligatorio Oli Usati” (www.coou.it; green line 800-863048). Parts consisting solely of plastic material, aluminium, steel, can be recycled if collected by the centres.



Cod:1140917_D



EUROCARDAN
ENERGY ON THE MOVE

14. QUICK CONSULTATION TABLES

The following pages, state the conditions and hypothesis of intervention for each of the cases stated above, in table form.

TIGHTENING TORQUES				
Threading	bolt class			
	8.8		10.9	
	Nm	Lb-ft	Nm	Lb-ft
M6	11	8.5	17	12
M8	28	20	40	30
M10	55	40	80	60
M12	95	70	140	105
M14	150	110	225	165
M16	240	175	305	225
M18	330	250	475	350

14.1 TABLE OF TIGHTENING TORQUES

Check the condition and the efficiency of all screws and bolts every day. If necessary, replace them immediately by requesting them from the manufacturer. Replace them in the exact original position (screw, washer, nut), observing the tightening torques given in the table next to them.

14.2 TROUBLESHOOTING



NOTE!

Follow the suggestions below one at a time, starting from the most basic ones and check if the fail was fixed by attempting to use the equipment. If the fault persists in spite of all the solutions, contact the

manufacturer's after-sales centres.

FAULT	CAUSE	REMEDY
Oil leak from the gear box or lateral drive sump	<ul style="list-style-type: none"> • Too much oil in the box or lateral sump • Breather plug with faulty valve • Top-up/drain/level caps loose • Damaged gaskets 	<ul style="list-style-type: none"> • Restore the proper oil level • Replace the breathing cap • Tighten the top-up/drain/level caps • Replace the gaskets
Tilling not uniform	<ul style="list-style-type: none"> • Tools worn or damaged • Machine not well adjusted (unaligned skids or rollers) • Machine clogged 	<ul style="list-style-type: none"> • Replace the tools • Carry out adjustments • Decrease tractor advancement speed • Clean the tilling chamber
Overheating of the conical couple unit	<ul style="list-style-type: none"> • Insufficient oil • Finished oil • Soil difficult to work 	<ul style="list-style-type: none"> • Top up oil • Restore oil level • Reduce advancement speed
Premature tool wear	<ul style="list-style-type: none"> • Sandy or muddy ground 	<ul style="list-style-type: none"> • Reduce advancement speed
Tools breakage	<ul style="list-style-type: none"> • Stony ground 	<ul style="list-style-type: none"> • Reduce advancement speed
Excessive power absorption	<ul style="list-style-type: none"> • Volume of land worked too high • Excessive work depth • Excessive rotor rotation speed • Tilling chamber clogging (damp land) 	<ul style="list-style-type: none"> • Decrease working depth by regulating skid heights • Reduce gear speed • Lift the rear cover to facilitate the escape of earth

14.3 LUBRICATION INTERVALS

RECOMMENDED LUBRICANTS	
OIL	AGIP-ENI BLASIA 150
GREASE	AGIP GREASE MU EP 2

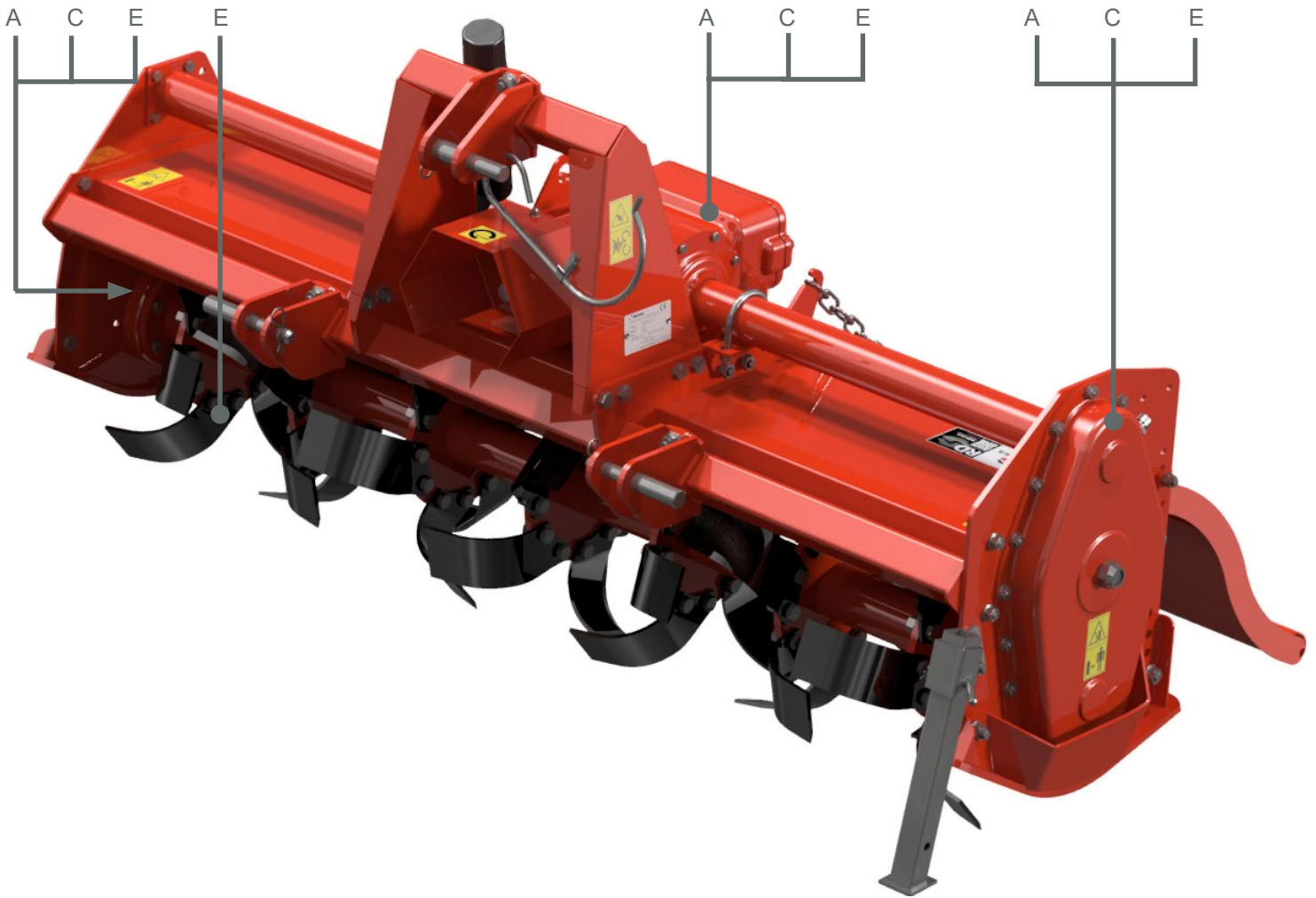

Ref.	INTERVAL IN HOURS	DESCRIPTION OF THE INTERVENTION
A	AFTER THE FIRST 50 WORKING HOURS	<ul style="list-style-type: none"> Replace the oil in the gearbox assembly Replace the gear side casing oil Replace rotor side support oil
B	EVERY 8 WORKING HOURS	<ul style="list-style-type: none"> Grease the rear roller supports (if present)
C	EVERY 50 WORKING HOURS	<ul style="list-style-type: none"> Check the oil level in the transmission assembly and top up if necessary Check the oil level in the lateral drive sump and top-up if necessary Check the oil level in the lateral support of the external rotor and top-up if necessary
D	EVERY 50 WORKING HOURS	<ul style="list-style-type: none"> Visually check the state of wear of the hoes and replace any damaged hoes or all, if required
E	EVERY 500 WORKING HOURS	<ul style="list-style-type: none"> Replacing the bevel transmission assembly oil Replacing the lateral casing oil

15. SPARE PARTS

Repairs and replacements of damaged or worn parts must be carried out using original parts, which must be requested from the Dealer or purchased via the website <https://SICMA.it/>. Please note that a request for spare parts must be accompanied by the following information:

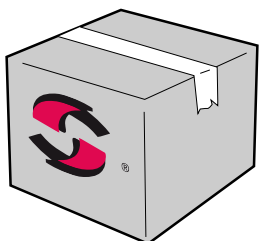

- Machine Type;
- Serial number;
- Code and description of the spare part requested can be obtained from the Spare Parts Exploded Diagram (<https://SICMA.it/>);
- Requested quantity.

Given the particular stress to which the equipment is subjected and for safety reasons, use exclusively original spare parts.



WARNING!

The use of non-original spare parts exempts SICMA from any responsibility for damage or injuries caused to operators, third parties and property and causes immediate forfeiture of the warranty.

16. WARRANTY

To benefit from the contractual warranty provided by the Manufacture, the operator must strictly comply with the instructions provided in the Use and Maintenance Manual, and in particular:

- Respect the limits for use set forth by the Manufacturer;
- Must not make any changes or modifications to the machine without the written approval of the Manufacturer;
- Do not bypass the safety guards;
- Always carry out all the required maintenance operations observing intervals and methods;
- Must only use original spare parts;
- Ensure that the personnel assigned to use the vehicle and equipment meet the necessary skill and training requirements.



SICMA S.p.A.
Contrada Cerreto, 39
66010 MIGLIANICO (CH) - ITALY
Tel. +39 087195841 - fax +39 0871950295