



Operator's Manual **TILLERS**

ATTENTION

Carefully read this manual
before using the machine

T5 T5GE T10 T10GE T15GE T20GE T25GE T30GE



Unifarm Machinery Corporation
PO Box 38, Wilson, NC, U.S.A.
252-291-3997 Fax: 252-291-7354

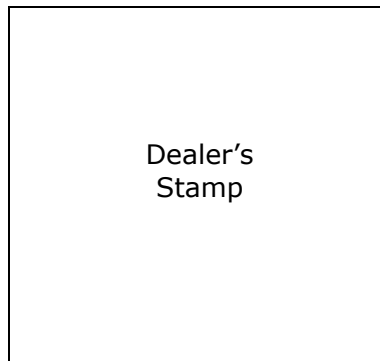

No part of this manual shall be reproduced, copied or disseminated by any means, without **Unifarm Machinery Corporation's** prior authorization in writing.

Unifarm Machinery Corporation reserves the right to make any necessary changes without giving prior notice, in order to optimize the quality and safety features and does not commit itself to updating this manual every time a change is made.

This booklet provides a thorough and accurate description of the instruction and maintenance activities to be carried out on the tiller you purchased. We congratulate you on your choice and urge you to thoroughly familiarize yourself with and follow the instructions contained in this manual. This will assure you a long, safe and trouble free working life for your Phoenix Tiller.

The Manufacturer shall not assume any responsibility should problems arise as a result of lack of compliance with the instructions and/or operator's negligence.

The manual is divided in chapters and paragraphs and the pages are numbered, thus offering accurate and precise information.

The requested information can be easily found by searching the key words or referring to the index.

INDEX

GENERAL INFORMATION

Symbols	Page 5
Safety labels	Page 6
Technical data	Page 7
Main parts	Page 8
Identification plates	Page 9
Recommended use	Page 9
Inappropriate use	Page 9
Torque specification table	Page 9

SAFETY

Safety in the workplace	Page 10
User's requirements	Page 10
Work clothing	Page 10
General safety norms	Page 11

SET UP

Attachment to the tractor	Page 12
Connection to PTO shaft	Page 13
Working depth adjustment	Page 14
Drag board adjustment	Page 14
Gearbox	Page 15
Chain adjuster	Page 15
Start up	Page 15
Road transport	Page 15
Shut down	Page 15

MAINTENANCE

First check	Page 16
Every 8 working hours	Page 16
Every 50 working hours	Page 16
Every 500 working hours	Page 16
Blade replacement	Page 17
How to order spare parts	Page 18

GENERAL INFORMATION

SYMBOLS

This booklet contains three "safety pictograms" which highlight the relevant danger levels or important information:



It draws the operator's attention to special situations which may jeopardize people's safety.



It draws the attention to situations which unfavourably affect the machine efficiency, but not people's safety.



It is used for general information, when people's safety or the efficiency of the parts are not at risk.

SAFETY LABELS

The safety labels and information on the machine, described below, must be complied with. Failure to comply with these warnings may result in severe injuries or even death. Make sure that the labels are always present and legible; should this not be the case, contact your nearest **Phoenix** dealer to request replacements.

! DANGER

1 MAKE SURE DRIVELINES ARE OF THE CORRECT LENGTH AND PROPERLY CONNECTED. DRIVELINE SEPARATION AND/OR PTO STUB SHAFT FAILURE CAN CAUSE INJURY OR DEATH. (See Operator's Manual for procedure)

SEE MANUAL FOR MINIMUM OVERLAP & MINIMUM MAXIMUM LENGTHS



BOTTOMING OUT



2 MAKE SURE THAT DRIVELINE SHIELDS ARE INSTALLED CORRECTLY AND TURN FREELY TO AVOID INJURY OR DEATH FROM ENT ANGLEMENT.

1



3 MAKE SURE THAT DRIVELINE IS INSTALLED CORRECTLY ON TRACTOR PTO SHAFT. MOVE YOKE BACK AND FORTH UNTIL LOCKING COLLAR CLICKS FORWARD AND LOCKS YOKE IN PLACE.

4 540 PTO RPM UNLESS SPECIFICALLY MARKED OTHERWISE.

4781001

! DANGER

FAILING TO FOLLOW SAFETY MESSAGES AND OPERATING INSTRUCTIONS CAN CAUSE SERIOUS BODILY INJURY OR EVEN DEATH TO OPERATOR AND OTHERS IN THE AREA.



2

1. READ OPERATOR'S MANUAL CAREFULLY AND PAY ATTENTION TO SAFETY DECALS FOR TRACTOR AND TILLER THOROUGHLY TO AVOID MISUSE, ABUSE, AND ACCIDENTS. PRACTICE BEFORE OPERATING.
2. OPERATE ONLY WITH ROPS AND FASTENED SEAT BELT TO AVOID INJURY AND POSSIBLE CRUSHING DEATH FROM OVERTURN. ALLOW NO RIDERS ON TRACTOR OR TILLER. FALLING OFF CAN CAUSE SERIOUS INJURY OR DEATH BY BEING RUN OVER BY TRACTOR OR TILLER OR BY BEING CUT BY THE ROTATING TILLER BLADES. ALLOW NO CHILDREN ON OR NEAR TILLER OR TRACTOR.
3. TO AVOID INJURY FROM FALLING OBJECTS WEAR HARD HAT, SAFETY GLASSES AND SHOES.
4. BUCK UP OR SUPPORT MACHINE SEVERELY BEFORE PUTTING HANDS OR FEET UNDER, OR WORKING UNDERNEATH LIFTED PARTS TO AVOID CRUSHING INJURY OR EVEN DEATH FROM SUDDEN, INADVERTENT DROPPING. MAKING SURE AREA IS CLEAR BEFORE LOWERING.
5. BEFORE TRANSPORTING, PUT LIFT LEVER IN LIFT (DETENT) POSITION AND FOLLOW TRAFFIC CODES. SLOW DOWN AT NIGHT, IN TURNS, & ON HILLSIDES.
6. MAKE SURE THAT SMV SIGN, WARNING LIGHTS, AND REFLECTORS ARE CLEARLY VISIBLE.
7. NEVER OPERATE WITH TILLER RAISED OF GROUND TO REDUCE POSSIBILITY OF INJURY FROM OBJECTS THROWN UNDER TILLER STRUCTURE.
8. BEFORE DISMOUNTING, SECURE TILLER IN TRANSPORT POSITION OR LOWER TO GROUND. STOP PTO. PUT TRACTOR IN PARK OR SET BRAKE, STOP ENGINE, AND REMOVE KEY. NEVER MOUNT OR DISMOUNT MOVING VEHICLE TO PREVENT POSSIBLE CRUSHING INJURY OR DEATH.



4781002

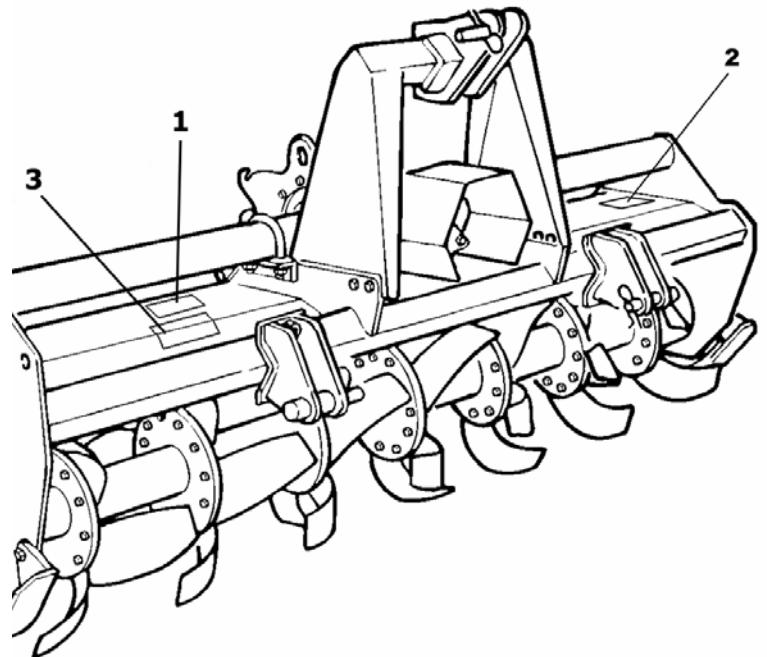

! WARNING

SHIELDS AND DEFLECTORS MAINTAINED IN BAD CONDITION MAY CAUSE INJURY OR DEATH FROM ENTANGLEMENT WITH ROTATING PARTS, BEING HIT BY OBJECTS THROWN WITH GREAT FORCE BY BLADES, OR BY BLADE CONTACT.

3

• Always replace Guards which have been removed for maintenance. Never operate with guard missing or broken.

• Chain Guards, Gearbox, Drivelines Shields, eventual Rubber-fabric Deflectors, and solid band enclosures are subject to wear and lost or broken parts must be replaced or repaired as soon as damage is found.

• Safety shielding must be installed and in good condition to avoid the possibility of thrown objects when the machine is operated in any area where thrown objects could cause injury.

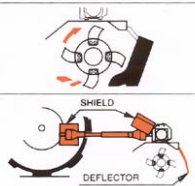

4781006

TECHNICAL DATA

Model	Width		HP	Weight		Working Depth		Gearbox	Side Drive		Blades (Qty)		Blades		
	cm	inch		kg	lbs	cm	inch		Chain	Gear	4	6	Curved	"L" Shaped	
T5	40	100	39	15-35	130	290	18	7	-	•	-	20	30	•	-
	44	110	44	15-35	140	312	18	7	-	•	-	20	30	•	-
T5 GE	48	120	47	15-35	145	323	18	7	-	•	-	24	36	•	-
	52	130	50	15-35	160	356	18	7	-	•	-	24	36	•	-
	56	140	55	15-35	175	389	18	7	-	•	-	28	42	•	-
T10	60	150	58	15-35	185	411	18	7	-	-	•	28	42	•	-
	58	145	57	30 - 50	260	577	18	7	-	•	•	28	42	•	•
T10 GE	66	165	65	30 - 50	275	610	18	7	-	•	•	32	48	•	•
	74	185	73	30 - 50	290	643	18	7	-	•	•	36	54	•	•
T15 GE	62	155	61	35-60	350	1443	20	8	-	-	•	24	36	•	•
	72	180	71	35-60	360	800	20	8	-	-	•	28	42	•	•
	80	205	82	35-60	390	866	20	8	-	-	•	32	48	•	•
T20 GE	68	170	67	40-70	445	987	20	8	-	-	•	28	42	•	•
	72	180	71	40-70	460	1012	20	8	-	-	•	28	42	•	•
	80	205	82	40-70	490	1087	20	8	-	-	•	32	48	•	•
T25 GE	90	230	90	40-70	530	1176	20	8	-	-	•	36	54	•	•
	80	205	82	60-90	605	1137	25	10	•	-	•	-	48	•	•
	90	230	90	60-90	630	1392	25	10	•	-	•	-	54	•	•
	100	255	100	60-90	655	1448	25	10	•	-	•	-	60	•	•
T30 GE	90	230	90	90-160	1050	2331	28	11	•	-	•	-	54	•	•
	100	255	100	90-160	1145	2541	28	11	•	-	•	-	60	•	•
	112	280	110	90-160	1215	2697	28	11	•	-	•	-	66	•	•
	120	305	120	90-160	1310	2908	28	11	•	-	•	-	72	•	•

IMPORTER:

Uniform Machinery Corporation
PO Box 38, Wilson, NC, U.S.A.

MAIN PARTS TERMINOLOGY

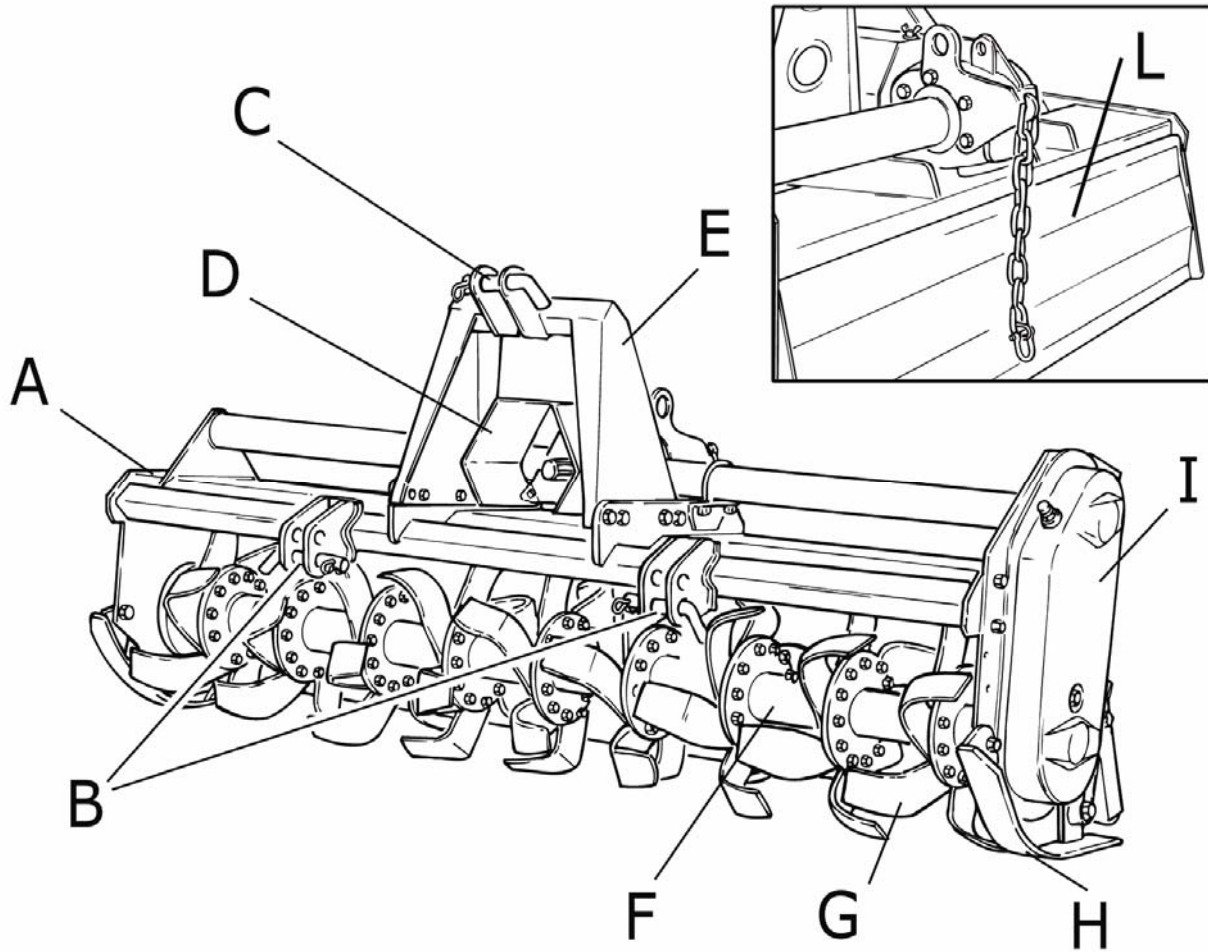

- A) Main Frame
- B) Lower Hitch Blocks
- C) Top Link Coupling
- D) PTO Shield
- E) Third Point Mast
- F) Rotor
- G) Tines
- H) Skids
- I) Transmission case
- L) Deflector

IDENTIFICATION PLATES

The identification plates are placed on all the tillers and are structured as follows:

Model of tiller (example):



Serial number (example):



When asking for information or service, always specify the machine type and the width.

RECOMMENDED USE

The tillers of **Unifarm Machinery Corporation**, described in this instruction and maintenance manual, have been designed explicitly to till the land. Any other use jeopardizes the operator's safety and the machine integrity.

INAPPROPRIATE USE

Unifarm tillers shall not be used as follows:

- Connected to vehicles which do not have a suitable power or weight.
- Without being properly installed by securing the hitch blocks to all three points of the tractor lift unit.
- Tilling of extremely stony or unsuitable ground.
- Raising or lifting of the equipment when the power take off is engaged.
- In close proximity to person/s when power is engaged.
- Do not stand or step on the equipment when it is being operated or transported.
- Do not operate the machinery while wearing unsuitable (loose fitting) clothing.

TORQUE SPECIFICATIONS

For correct hardware tightening on the tiller, we suggest the use of suitable torque wrench and the applicable torque as listed in the table below:

M-THREADED SCREW/BOLTS				
Bolt grade				
Thread	8.8		10.9	
	Nm	Lb-ft	Nm	Lb-ft
M6	11	8.5	17	12
M8	28	20	40	30
M10	55	40	80	60
M12	95	70	140	105
M14	150	110	225	165
M16	240	175	305	225
M18	330	250	475	350

SAFETY

SAFETY IN THE WORKPLACE

Most of the accidents, which occur while the operator is using the machine or the equipment or carrying out maintenance and repair activities, are caused by the non-compliance with the main safety requirements.

Therefore the potential risks must be fully understood and special attention must be paid to the activity which is being executed.

**If potentially dangerous situations are known,
accidents can be prevented!**

USER'S REQUIREMENTS

The equipment user must have the following:

Physical: good sight, co-ordination and capability to execute all instructions in a safe manner.

Mental: the users must understand and follow the prescribed norms, rules and safety measures. They must be careful, pay attention to their own safety and the safety of other people and act properly and in a responsible way.

Training: the users must read and understand this manual, its pictures and charts, and the identification and hazard plates. They must be trained and qualified to perform any use and maintenance activities.

WORK CLOTHING

The following clothing and personal protective equipment must be used when working and executing maintenance and repair activities:

- Overalls or any other comfortable outfit; make sure that they are not too loose since they might be caught by moving parts.
- Protective gloves.
- Goggles or mask to protect the eyes and face.
- Safety helmet.
- Safety shoes.



Make sure that the personal protective equipment is properly stored and complies with the laws in force.

GENERAL SAFETY NORMS

The features of the area where work is taking place must always be taken into consideration:

- Do not stand in the working radius of the operating machinery or any other machine accessories when the equipment is running.

Prepare the work:

- Do not drink alcohol, take drugs, or any other substances which may affect the your ability to use the equipment before or when working.
- Make sure that there is sufficient fuel in the tractor to prevent the machine from stopping during work.
- Do not use the equipment under unsafe conditions, e.g. do not make temporary repairs just to start or keep working; do not work at night if the area is not well illuminated.

When working or executing maintenance activities, remember:

- The labels and stickers providing instructions on the use of the equipment or information on dangers must not be removed or hidden, and must be legible.
- Do not remove the safety devices, covers and safety guards, unless maintenance activities are being carried out. If the safety devices must be removed, turn the engine off, remove them correctly and re-install them before turning the tractor on.
- Do not lubricate, clean or adjust moving parts.
- Use the appropriate tools to execute maintenance or adjustment activities on the equipment.
- Do not use damaged or unsuitable tools, e.g. pliers rather than wrenches etc.
- Prior to carrying out activities on hydraulic lines under pressure, or disconnecting their components, make sure that the line is no longer under pressure and that it does not contain any hot fluids.
- Check all the fittings and make sure that they are well connected before supplying pressure to the hydraulic lines.
- Make sure that no tools, clothes or any other materials are left in areas where moving parts are present when the maintenance and repair activities are completed.
- Do not give directions and make signals at the same time during a manoeuvre. Manoeuvre directions and signals must be given from one person only.
- Do not unexpectedly call an operator, if not necessary. Do not startle the operator, e.g. by throwing objects.
- Pay attention to people in the vicinity of the work area, especially children!
- Make sure that nobody is standing in the working range of the equipment.
- Do not use the equipment to lift people.
- When the equipment is not needed, turn the engine off, leave the vehicle on a flat surface, with the first gear and the parking brake engaged. Disengage the power take off.
- Do not execute any cleaning, lubrication, repair or adjustments when the engine is running and the equipment is in the raised position.
- Do not work on steep slopes, if the stability of the vehicle can be jeopardized.

UNIFARM MACHINERY CORPORATION shall not assume any responsibilities if these instructions are not strictly followed.

SET UP

ATTACHMENT TO THE TRACTOR

Carefully read this instruction manual and the manuals of the tractor and PTO shaft manufacturer. All **Phoenix** tillers are built to be attached to any tractor equipped with a three point lift of the correct category and with suitable ball ends.

Before attaching the equipment to the tractor, make sure that the ground is smooth and flat and that nobody is standing between the tractor and the tiller; slowly move the tractor towards the tiller by aligning the tractor lifter arms with the two tiller coupling side pins; turn the engine off and pull the brake.

It is possible to adjust the attachment position releasing the bolts **B** (picture 3) and modifying the position of the plates **A** (on the tillers **T5, T10, T15, T20**). Tighten the bolts after making any adjustment.

On the tillers **T25, T30** it is possible to change the lower position of the floating brackets by inserting the pin **A** in the lower hole **B**, as shown in picture 4, or do the opposite.

picture 3

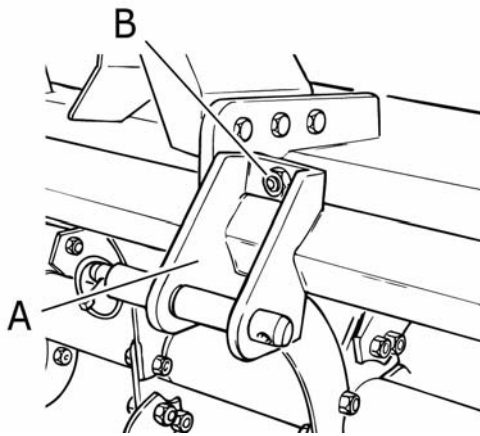

picture 4

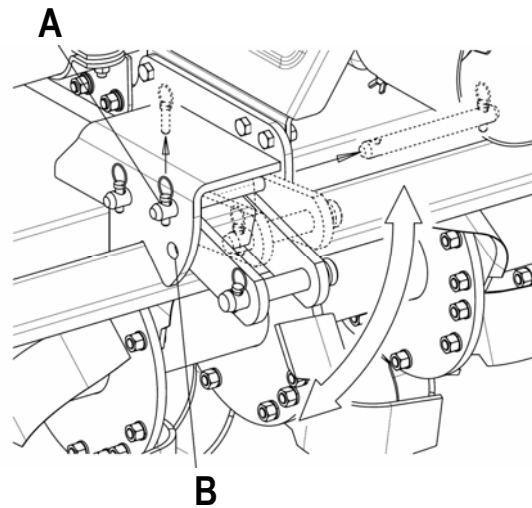

After adjusting the couplers, connect the lower arms by removing the catch pins from the pins located on the hitch blocks, inserting the lift arm pins through the hitch block and ball ends and secure them by means of the pins which were previously removed.

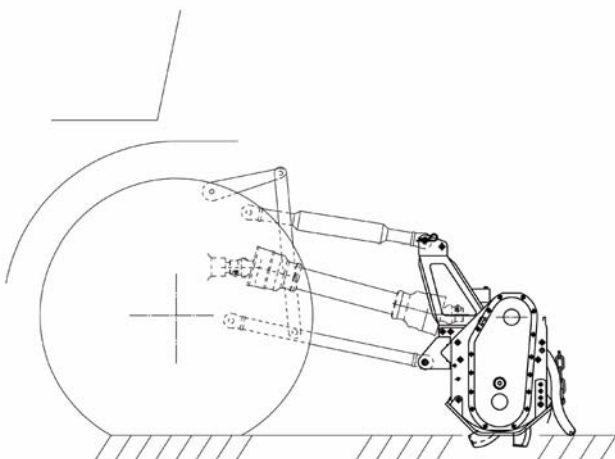

Connect the tractor top link to the third upper point by removing the pin located between the two plates, inserting the top link and securing it by means of the pin.

Adjust the top link so that the upper part of the frame is parallel to the ground. Block all the linking parts by means of the sway chains or arms.

Make sure that the central unit axis (case/bevel gear pair) is parallel to the ground, thus minimising the stresses on the power take off and increasing the working life of the equipment.

Caution

After executing all the above-mentioned activities, make sure that all the nuts and bolts are tightened.

CONNECTION TO THE PTO SHAFT

Before installing the PTO shaft make sure that the RPM rating and the direction of rotation match those of the tractor. Carefully read the PTO shaft and tractor instructions.

Furthermore, accurately read the instructions of the manufacturer of the PTO shaft and of the tractor.

Before starting any activity, make sure that the guards are installed on the power take off of the tractor and PTO shaft. Make sure that they cover the PTO shaft throughout its length.

Caution

When fully extended, the plastic pipes must overlap by at least 1/3 of the length of the pipes (LT). When retracted, the min. acceptable clearance is 1-2 cm (picture 6).

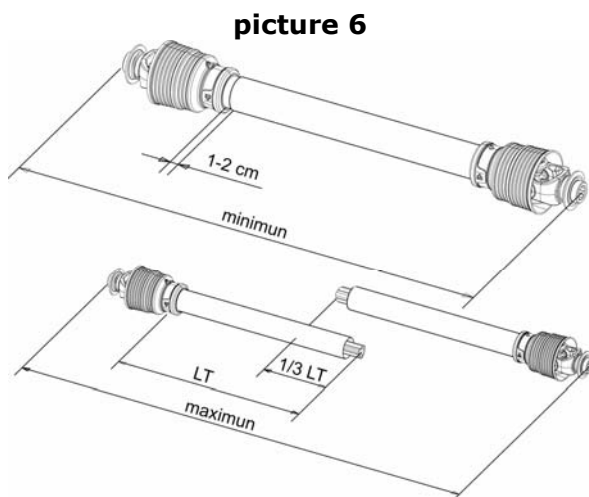

Check that the PTO shaft min. and max. length are within the parameters of the machine-tractor coupling.

Should problems arise, contact your dealer. After the installation, anchor the PTO shield to the tractor and machine using the special chains; make sure that it turns smoothly. If the PTO shaft is equipped with safety devices, e.g. torque limiters or free-wheel devices, install them on the operative machine side. For the use and maintenance of the PTO shaft, please refer to the relevant manual.

WORKING DEPTH ADJUSTMENT

The working depth of the equipment depends on the position of the lateral skids. If the skids are raised, the working depth increases; if the skids are lowered, the working depth decreases.

Make sure that the skids are set at the same height on both sides.

To adjust the working depth on the **T5, T10, T15, T20** tillers loosen and remove nut **A** (picture 7) and adjust the skid height according to the holes **B**. When the adjustment is completed, tighten the screws.

To adjust the working depth on the **T25, T30** tillers loosen nut **A** (picture 8) adjust the rod **B** until you reach the requested height. When the adjustment is completed, tighten the screws.

picture 7

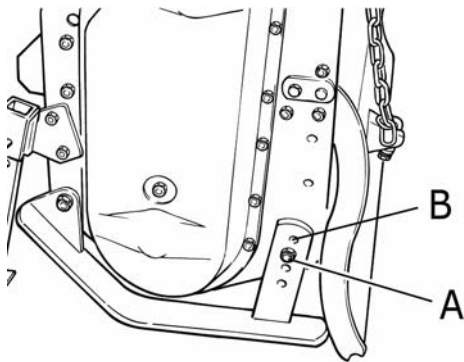

picture 8

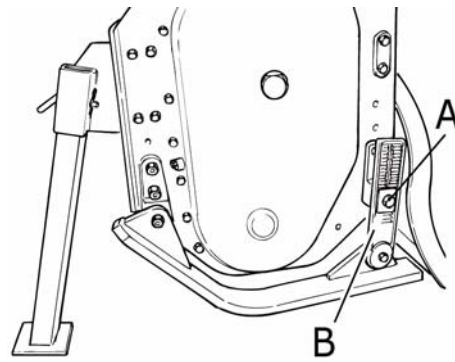

DRAG BOARD ADJUSTMENT

The height of the rear drag board can be adjusted, making the ground more compact and smooth. Release the chain **A** (picture 9) and re-engage it at the desired height **B**.

picture 9

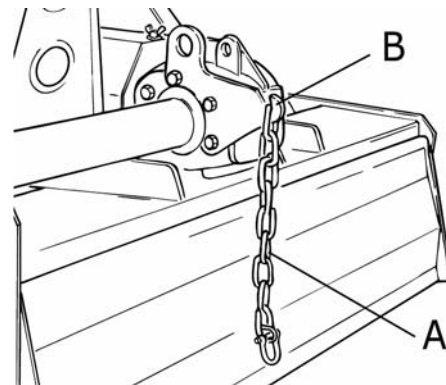

These activities must be carried out with the engine off, the power take off disengaged and the hand brake applied. If needed, lift the equipment and place it on supports, thus preventing any injuries that might be caused by a sudden fall of the equipment.

GEARBOX

The **T25, T30** tillers are equipped with a gearbox and it is possible to change the rotor speed independently from the speed of the tractor's PTO.

High speed improves the soil working, but rotating parts wear more quickly.

To change the speed on the **T25, T30** tillers, remove the cover **A** (picture 10) of the box and invert the gears **B** and **C** at the inner side; it is possible to obtain other two speeds by replacing the fixed gears with the ones placed on the cover.

For the gearbox speed refer to the labels on the machine.

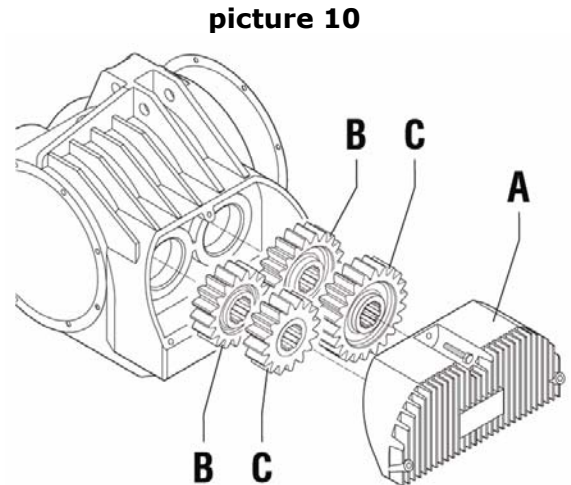

Adjust the gearbox with the engine shut off, the power take off disengaged, the parking brake engaged, and the equipment resting on the ground.

CHAIN ADJUSTER

On the **T5, T10** tillers are equipped with a chain drive, the chain adjustment is made during assembly. Any adjustments when using the machines, must be carried out by an authorized dealer or work shop.

START UP

After carrying out these adjustments, the equipment is ready for use. When at the working area, do not start the power take off with the tiller in working position in the ground. Be sure to lift it by a few centimetres using the tractor lift. Start the engine, engage the power take off, lower the equipment to its working position and start.

ROAD TRANSPORT

With reference to road transport, follow local traffic regulations.

SHUT DOWN

The following activities are recommended if the tiller will not be used for a long period of time:

- 1 Clean and dry the equipment.
- 2 Inspect the equipment and replace the damaged or worn parts if necessary.
- 3 Tighten all the screws and nuts.

Lubricate and cover the machine with a tarpaulin and store it in a dry place.

MAINTENANCE

Maintenance is crucial for the working life and efficiency of any agricultural equipment. If the equipment is properly maintained and operated, a long working life and operator safety are assured.

The maintenance intervals indicated in this booklet are provided as a mere reference and are related to normal working conditions; changes may occur depending on the type of activities, environmental dust, seasonal factors, etc.



- **Before injecting lubricating grease into the grease fittings, clean the fittings to prevent mud, dust, or any other foreign matter from contaminating the grease and reducing the lubrication effect.**
- **When adding or changing the oil, use the same type of oil to prevent mixing oils with different features.**
- **All maintenance activities must be carried out with the tiller resting horizontally on the ground, with the engine off and not overheated.**
- **After using the equipment for a few hours, make sure that all the bolts (especially tine bolts) are tightened; regularly check all the machine guards.**

FIRST CHECK

- After 50 working hours, change the oil in the gearbox and make sure that all the screws and bolts are tightened.

EVERY 8 WORKING HOURS

- For the **T10** tillers grease the rotor support through the grease fitting **A** (picture 11).
- Grease the PTO shaft crosses.

EVERY 50 WORKING HOURS

- Check the oil level in the case/bevel gear pair by removing gearbox's upper oil plug (**A** - picture 14); oil level should be about at half of gearbox. If the model is equipped with dip stick oil plug (**B** - picture 12), make sure that the oil level is contained between the 2 nicks of MIN & MAX.
- Check the oil level in the side transmission (**A** - picture 13) and in the **T15, T20, T25, T30** tillers check the oil level in the rotor support (**A** - picture 14). If needed add SAE EP 80W90 oil.
- Make sure that all the screws and bolts, especially on the blades, are tightened.

EVERY 500 WORKING HOURS

- Change the oil of the case/bevel gear pair, side transmission and rotor support (**T15, T20, T25, T30**); use SAE EP 80W90 oil. Contact the closest **Phoenix** dealer for this maintenance activity.

picture 11

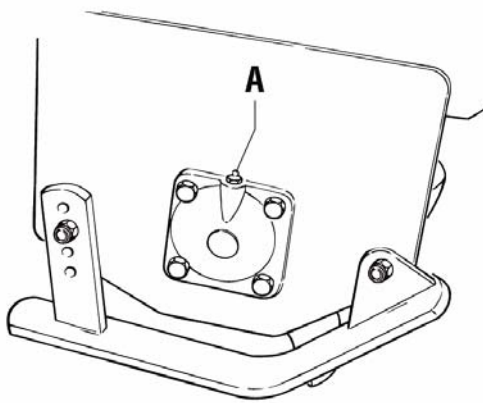

picture 12

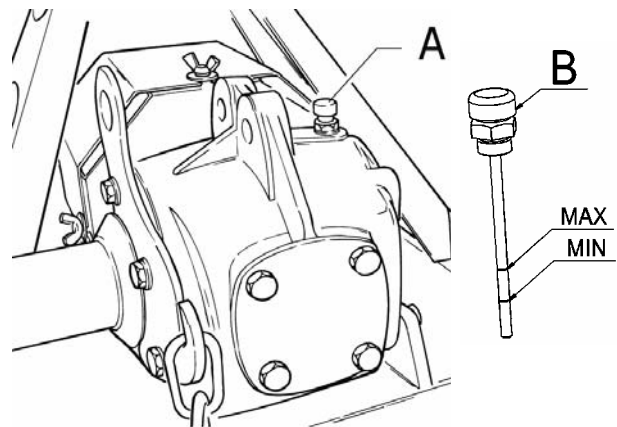

picture 13

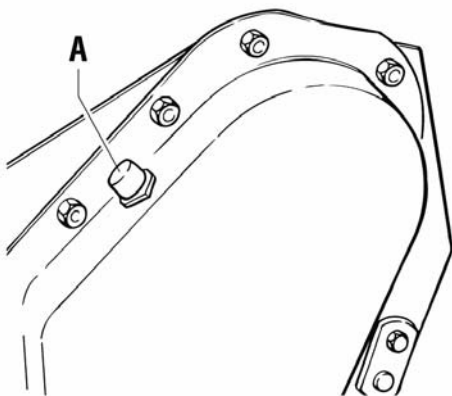

picture 14

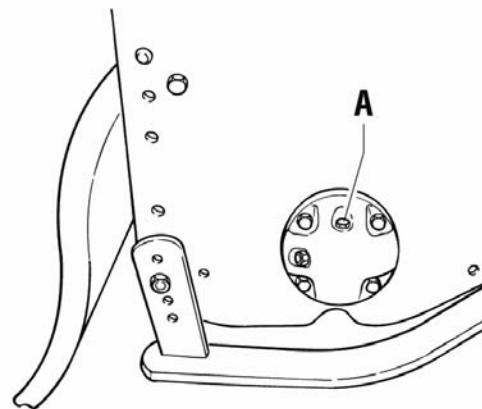

! Caution

The old oil must be disposed of in compliance with the local laws where these activities are carried out; do not spill or dispose of waste oil on the ground.

! Danger

The maintenance activities must be carried out with the engine off, the power take off disengaged, the parking brake engaged, and the equipment placed on the ground.

BLADE REPLACEMENT

To assure the optimum efficiency of the machine, make sure that the tiller blades are in a good working condition and that their bolts are tightened; replace them if they are broken or bent. The new parts must be installed in the original position.

The **T5, T10, T15, T20, T25, T30** tillers are equipped with 6 blades per flange; but it is possible to reduce the number to four blades per flange (except for **T25, T30** tillers), in case special ground conditions require this modification.

Danger

Before replacing the blades, turn the tractor engine off, pull the parking brake, disengage the power take off, raise the tiller using the tractor lift, and install supports to prevent accidental dropping of the machine.

Pay special attention to the bolts **A** on the blades (picture 15): the screw head must be placed on the blade side, with the washer and the nut on the flange side, so that the bolts cannot loosen while the equipment is being used.

When several blades must be replaced, replace one blade at a time, so that the initial helical layout is maintained (picture 16).

picture 15

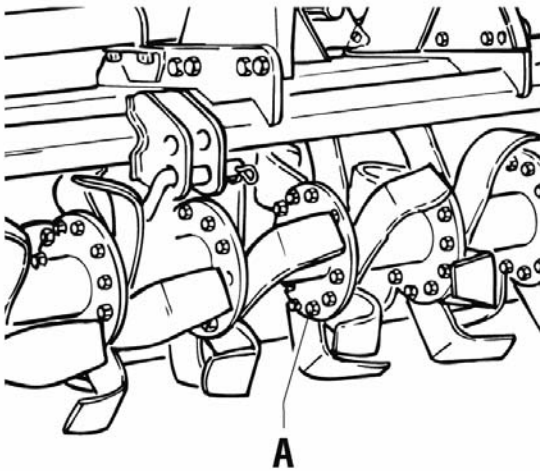

picture 16

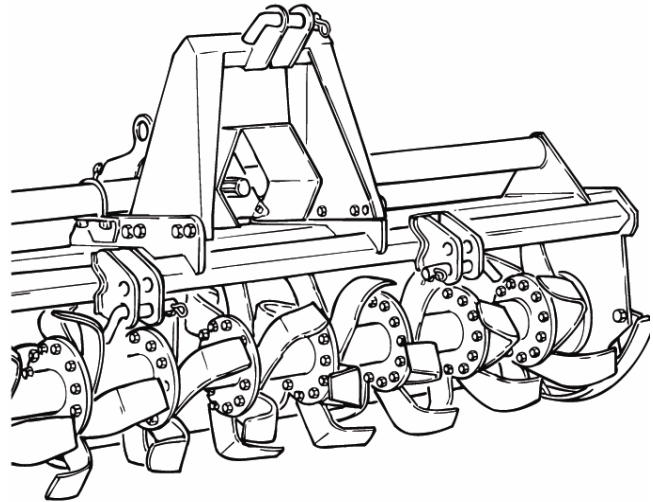

HOW TO ORDER SPARE PARTS

For spare parts requests please refer to the spare parts catalog.

The spare parts can be ordered from the dealer or service center. The following data must always be specified:

- Equipment type and width.
- Part number of the requested component. If the code number is missing, indicate the table number in which it is shown and the relevant reference.
- Description of the part and requested quantity.
- Requested type of transport. Should this information not be provided, the dealer or service center shall not be responsible for delays caused by circumstances beyond their control. The addressee shall be responsible for any transport charges.

Uniform Machinery Corporation

PO Box 38, Wilson, NC
252-291-3997 Fax: 252-291-7354